



swisherinc.com

OWNER'S MANUAL

MODEL NO.
LS412

STARTING SERIAL #:
L205-332001

IMPORTANT

Read and follow all Safety
Precautions and Instructions
before operating this
equipment.

Rev.

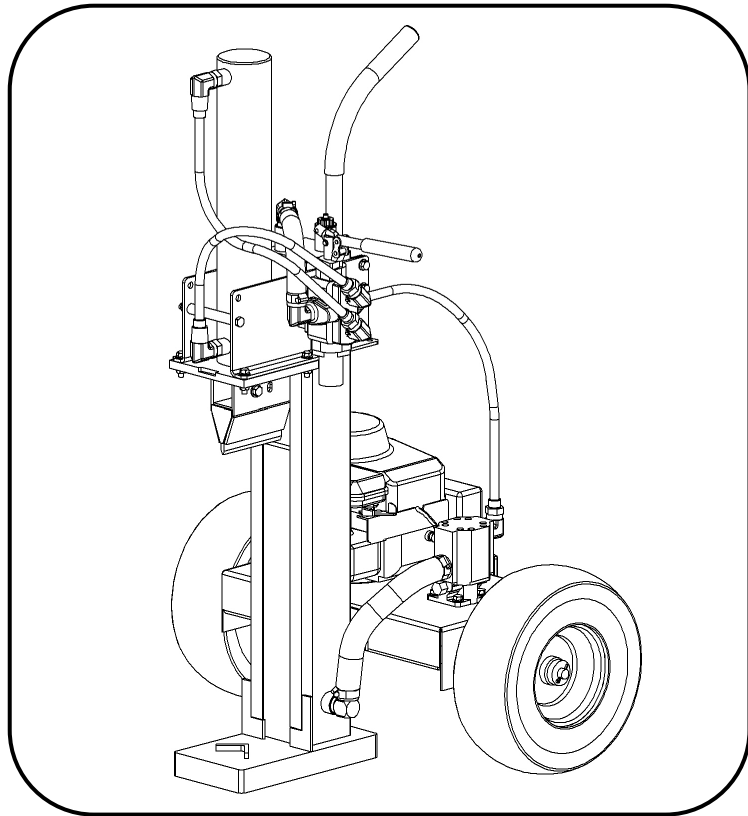

LOG SPLITTER

Safety
Assembly
Operation
Service and Adjustment
Repair Parts

1602 CORPORATE DRIVE, WARRENSBURG, MISSOURI 64093 PHONE 660-747-8183
FAX 660-747-8650

Manufacturing quality lawn care equipment since 1945

Made In The
USA

LIMITED WARRANTY

The manufacturer's warranty to the original consumer purchaser is: This product is free from defects in materials and workmanship for a period of ONE (1) year from the date of purchase by the original consumer purchaser. We will repair or replace, at our discretion, parts found to be defective due to materials or workmanship. This warranty is subject to the following limitations and exclusions:

- 1) Engine Warranty All engines utilized on our products have a separate warranty extended to them by the individual engine manufacturer. Any engine service difficulty is the responsibility of the engine manufacturer and in no way is Swisher Mower Co., Inc. or its agents responsible for the engine warranty. The Briggs & Stratton Engine Service Hot-Line is 1-800-233-3723.
- 2) Commercial Use The warranty period for any product used for commercial or rental is limited to ninety (90) days from the date of original purchase.
- 3) Limitation This warranty applies only to products which have been properly assembled, adjusted, and operated in accordance with the instructions contained within this manual. This warranty does not apply to any product of Swisher Mower Co., Inc., that has been subject to alteration, misuse, abuse, improper assembly or installation, shipping damage, or to normal wear of product.
- 4) Exclusions Excluded from this warranty are normal wear, normal adjustments, and normal maintenance. The pump, valve, and cylinder each carry separate manufacture's warranties. The valve and cylinder both carry a one (1) year limited warranty. The pump carries a two (2) year limited warranty.

In the event you have a claim under this warranty, you must return the product to an authorized service dealer. All transportation charges, damage, or loss incurred during transportation of parts submitted for replacement or repair under this warranty shall be borne by the purchaser. Should you have any questions concerning this warranty, please contact us toll-free at 1-800-222-8183. The model number, serial number, date of purchase, and the name of the authorized Swisher dealer from whom you purchased the splitter will be needed before any warranty claim can be processed.

THIS WARRANTY DOES NOT APPLY TO ANY INCIDENTAL OR CONSEQUENTIAL DAMAGES AND ANY IMPLIED WARRANTIES ARE LIMITED TO THE SAME TIME PERIODS STATED HEREIN FOR ALL EXPRESSED WARRANTIES. Some states do not allow the limitation of consequential damages or limitations on how long an implied warranty may last, so the above limitations or exclusions may not apply to you. This warranty gives you specific legal rights and you may have other rights, which vary from state-to-state. This is a limited warranty as defined by the Magnuson-Moss Act of 1975.

TABLE OF CONTENTS

WARRANTY.....	2	MAINTENANCE.....	6-7
SAFETY PRECAUTIONS.....	3-4	DECALS.....	7
ASSEMBLY.....	5	PARTS BREAKDOWN.....	8-9
OPERATION.....	5-7	SPECIFICATIONS.....	11

SAFETY PRECAUTIONS



This Safety Alert Symbol indicates important messages in this manual. When you see this symbol, carefully read the message that follows and be alert to the possibility of personal injury.

Read this manual completely. This machine can amputate hands, feet, and throw objects. Failure to observe the following safety instructions could result in serious injury or death.



WARNING: The engine exhaust from this product contains chemicals known to the state of California to cause cancer, birth defects or other reproductive harm.



DANGER: Your log splitter was built to be operated according to the rules for safe operation in this manual. As with any type of power equipment, carelessness or error on the part of the operator can result in serious injury. If you violate any of these rules, you may cause serious injury to yourself or others.

- Read and understand the manual. Learn to operate this equipment in a safe manner. Familiarize yourself with all of the controls in a safe environment before starting to work with this machine.
- **DO NOT** under any circumstances alter this log splitter. This equipment was designed and engineered in accordance with operating instructions. Altering this equipment, or using this equipment in such a way as to circumvent its design capabilities and capacities, could result in serious injury or fatality and **WILL VOID THE WARRANTY**.
- Allow **ONLY** responsible adults who have read this manual to operate this machine. **NEVER** allow children to operate this machine.
- **NEVER** operate or allow someone to operate this equipment while under the influence of alcohol, drugs or medication. Being coherent is essential for safety.
- **ALWAYS** use outdoors with adequate ventilation. **DON'T** run the engine in an enclosed area. Exhaust gases contain carbon monoxide. This odorless gas can be deadly when inhaled.
- **NEVER** use splitter for any other purpose than splitting wood. Any other use can result in injury. Your splitter is a precision piece of power equipment, not a toy. Therefore, exercise extreme caution at all times.
- **ONLY** a single operator is to load and operate the log splitter. **KEEP** all others, including pets and children, a minimum of 20 feet away from your work area. More accidents occur when more than one person operates the log splitter than any other time.
- **ALWAYS** wear protective gear such as safety goggles, protective hearing device, steel-toed shoes, and tight-fitting gloves without drawstrings or loose cuffs.
- **NEVER** wear loose clothing or jewelry that can be caught by moving parts of the splitter and pull you into it. Keep hair away from moving parts.
- **NEVER** operate your splitter on wet, muddy, or icy surfaces. **KEEP** work area clean of split wood. Safe footing is essential in preventing accidents.
- **ONLY** operate splitter on level ground with wheels blocked, not on the side of a hill. It could tip, or rolling logs, poor footing, etc. could cause an accident.

- NEVER operate your splitter near a flame or spark. Hydraulic oil and gasoline are flammable and can explode.
- NEVER fill gas tank while the engine is hot or running. Allow the engine to cool before refueling.
- This unit is equipped with an internal combustion engine and should not be used on or near any unimproved forest-covered, brush-covered or grass-covered land unless the engine's exhaust system is equipped with a spark arrester meeting applicable local or state laws (if any). If a spark arrester is used it should be maintained in effective working order by the operator.

-NOTE-

In the state of California, the above is required by law (Section 442 of the California Public Resources Code). Other states may have similar laws. Federal laws apply on federal lands. A spark arrester muffler (optional by manufacturer) is available at your nearest engine dealer. Check legal requirements in your area.

- ONLY use your hands to operate the control lever. NEVER use foot, knee, rope or any extension device.
- Split ONLY one log at a time. NEVER attempt to split two logs on top of each other.
- NEVER place hands or feet between log and splitting wedge or between log and ram during forward or reverse stroke. ALWAYS keep fingers clear of splits that open in log during splitting operation.
- DO NOT straddle or reach across the splitting area while operating the splitter.
- DO NOT step over splitter when the engine is running. You may trip or accidentally activate the splitting wedge. Walk around to get to the other side.
- NEVER attempt to load splitter while splitting wedge is in motion. When loading log splitter, place hands on the sides of the log, not the ends.
- NEVER attempt to split woods across the grain. Wood may burst or fly out of your splitter and result in serious injury.
- NEVER leave your splitter unattended with the engine running. Shut off the engine if you are leaving your splitter, even for a short period of time. Someone could accidentally activate the ram and be injured.
- Both ends of the log should be cut as squarely as possible to prevent the log from sliding out of the splitter during operation. Log length should be kept to 19" or less.
- NEVER allow persons to ride on splitter. DO NOT carry any cargo or wood on your splitter. It may fall off and cause an accident.
- DO NOT loosen or remove any hydraulic fitting, line or reservoir cap while your splitter or engine is running.
- Fluid escaping from a very small hole can almost be invisible. DO NOT check for leaks with your hand. See maintenance section for instructions. **IF injured by escaping fluid, see a doctor at once. Serious infection or reaction can develop if proper medical treatment is not administered immediately.**
- DO NOT operate your splitter in poor mechanical condition or when it is need of repair.
- ALWAYS disconnect the spark plug wire and place the wire where it cannot contact the spark plug, to prevent accidental starting the engine when setting up, transporting, adjusting or repairing.

ASSEMBLY

This log splitter has been partially assembled at the factory. Refer to the drawings and part lists should it become necessary to disassemble the unit for repair or replacement of parts.

Inspect all components for damage. If you believe you have a damaged part please contact customer service immediately at 1-800-222-8183.



WARNING: Exercise extreme caution, as parts are very heavy. Sufficient persons or mechanical handling equipment should be used.

Refer to uncrating and assembly instructions for assembly procedures.

OPERATION

INTENDED USE: This log splitter is intended and designed to only split wood. NEVER use for any other purposes. Doing so can cause injury or VOID THE WARRANTY.

IMPORTANT: This unit is shipped with oil but without gasoline in the engine. After assembly, see separate Engine Manual for proper fuel and oil recommendations.



WARNING: *DO NOT START OR RUN THE LOG SPLITTER WITHOUT OIL IN THE ENGINE AND HYDRAULIC RESERVOIR.*

FILLING THE HYDRAULIC RESERVOIR

Fill the hydraulic reservoir with approximately 6 Quarts of general-purpose automatic transmission fluid or general-purpose hydraulic fluid. After the hydraulic reservoir and the engine crankcase are filled correctly with their respective oils, start the engine. Remember to set the throttle and turn on the fuel shut-off valve. The hydraulic pump should prime itself. With the engine running, move the hydraulic valve lever toward the wedge. This will cause the cylinder to extend and expel air. When the cylinder is fully extended, retract it. Repeat this procedure several times. (An erratic movement of the cylinder indicates that there is air in the system). Once the cylinder has a smooth and constant speed indicating that all air has been expelled, add another 2 quarts of oil. Fluid level should be maintained approximately 3” below the fill hole and above the flat on the dipstick. This model requires approx. 9-10 Quarts of hydraulic fluid.

NOTE: If the tank is overfilled, it will tend to expel oil from the breather cap when the cylinder is retracted.

START UP



WARNING: *DO NOT START OR RUN THE LOG SPLITTER WITHOUT OIL IN THE ENGINE AND HYDRAULIC RESERVOIR.*

See separate Engine Manual for fuel and oil recommendations. If applicable your log splitter has come equipped with a fuel shut-off valve for towing purposes.

Before starting engine make sure crankcase is filled correctly with oil and the proper fuel has been used. The engine will only start when the throttle lever and fuel shut-off valve if applicable are turned to their ON positions.

STARTING INSTRUCTIONS

Briggs & Stratton 4HP Engine

1. Move throttle control to “FAST.”
2. Push primer bulb three (3) times. **NOTE:** Do not use primer to restart a warm engine after a short shutdown.
3. Grasp rope handle and pull out slowly until resistance it felt. Then pull rapidly with a full arm stroke. **NOTE:** If engine fails to start after three (3) pulls, repeat steps 1 and 2.
4. When Engine starts, leave throttle control at “FAST.” The throttle must be set in the fast position for maximum performance.
5. To stop engine, move throttle lever to “SLOW” for a few seconds then to “STOP.”

SPLITTER OPERATION

1. Set up the log splitter in a clear, level area and block the wheels. The suction port on the tank should always be on the lower side of the log splitter.
2. Place a log on the beam, against the foot plate. Make sure the log is securely on the foot plate and up against the beam.
3. Depress the valve lever so that the cylinder will drive the push block into the log. Extend the cylinder until the log splits or to the end of its stroke. If the log has not completely split after the cylinder has reached the end of its extension, retract the cylinder. **NOTE:** Leaving the valve in the “actuate” position at the end of the stroke may damage the pump. Always use extra care when splitting logs with ends that are not square.

NOTE: To extend the life of the hydraulic cylinder, avoid “BOTTOMING OUT” the cylinder.

HYDRAULIC SAFETY

The hydraulic system on your splitter requires careful inspection along with the mechanical parts. Be sure to replace any frayed, kinked, cracked or otherwise damaged hydraulic components. Just because it isn't leaking today doesn't mean that it will not fail tomorrow.

Fluid escaping from a very small hole can almost be invisible. Do not check for leaks with your hand. Escaping fluid under pressure can have sufficient force to penetrate skin causing serious personal injury or even death. Leaks can be detected by passing a piece of cardboard or wood over the suspected leak and looking for discoloration. **IF injured by escaping fluid, see a doctor at once. Serious infection or reaction can develop if proper medical treatment is not administered immediately.**

Should it become necessary to loosen or remove any hydraulic fittings, lines or reservoir cap, be sure to relieve all pressure by shutting of the engine and moving the control handle back and forth several times.

NEVER remove the cap from the hydraulic tank or reservoir while the unit is running. Hot oil under pressure could result in serious injury. See also **SAFETY PRECAUTIONS**.

The pressure relief valve on your splitter is preset at the factory. DO NOT adjust the valve. Only a qualified technician should perform this adjustment.

MAINTENANCE AND STORAGE

WARNING: *DISCONNECT THE SPARK PLUG BEFORE PERFORMING ANY MAINTENANCE.*

Consult the operating and maintenance instructions of the engine manufacturer for engine care.

Always check the oil level of the hydraulic reservoir before operation. Operating without an adequate oil supply will cause severe damage to the pump. Fluid level should be maintained approximately 3” below the fill hole and above the flat on the dipstick.

Periodically check that all nuts, bolts, screws, clamps and fittings are tight and secure.

To keep your splitter in top working condition perform all recommended maintenance procedures before you use your splitter.

If the wedge becomes dull or nicked a grinder or sharpening tool can be used to sharpen it.

Completely drain the fuel tank prior to storage. Always store gasoline in an approved, tightly sealed container. Store container in a dry, cool place with adequate ventilation. Keep fuel away from areas where fumes could contact open flame, pilot light or sparks.

Be aware of the environment when disposing of used petroleum products. Please dispose of used hydraulic fluid, engine oil and any by products from the maintenance of your splitter at approved recycling centers.

Should it become necessary to disassemble the unit for repair or replacement of parts, refer to the drawings and parts list on the following pages. Exercise extreme caution, as some parts are very heavy and will require sufficient persons or mechanical handling equipment.

Your Swisher Log Splitter has been produced with components designed specifically to this machine. Although standard springs, hardware and ect may look similar to parts used on other machinery, they may in some cases be made of a different construction and/or materials. All replacement parts must meet manufacturer’s specifications.



The operation of any splitter can produce foreign objects to be thrown into the eyes, resulting in severe eye damage. Always wear certified safety glasses or wide-vision safety goggles over spectacles before starting any splitting machine and while operating such a machine.



The operation of any splitter produces sound waves that are damaging to the human ear. Ear protection is recommended.

SAFETY DECALS

Replace decals immediately if damaged.



OD16 – FUEL SHUT OFF DECAL

(NOT ALL MODELS)

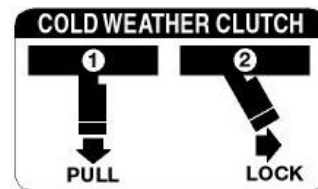

OD07 – COLD WEATHER DECAL



OD12 – HYDRAULIC FILL PLUG DECAL

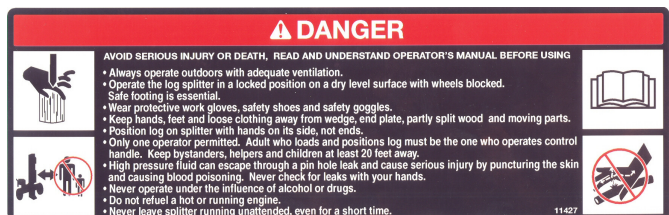

11427 – LS DANGER DECAL

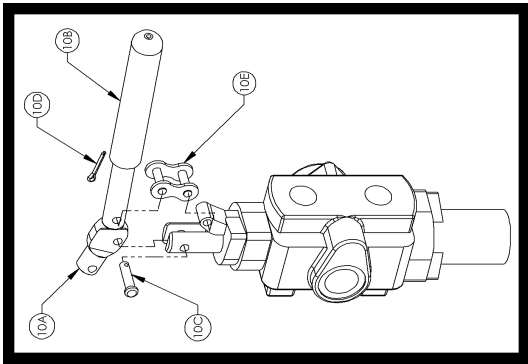

VALVE DETAIL

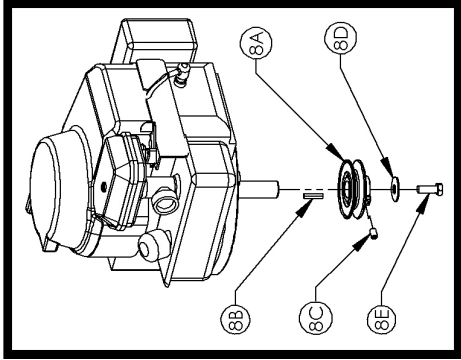

ENGINE DETAIL

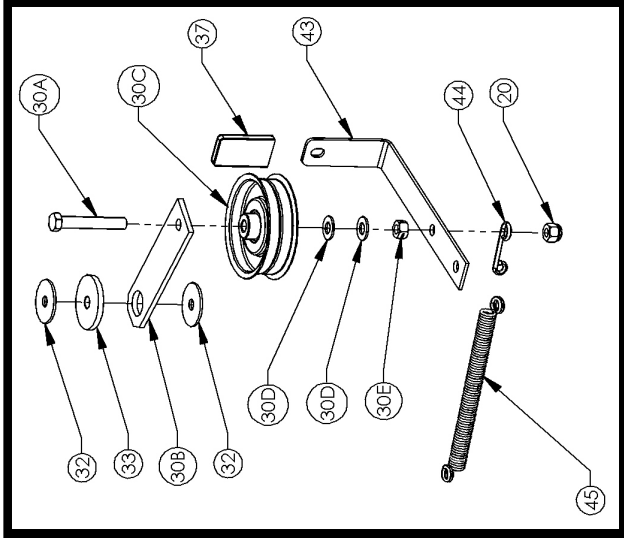

IDLER DETAIL

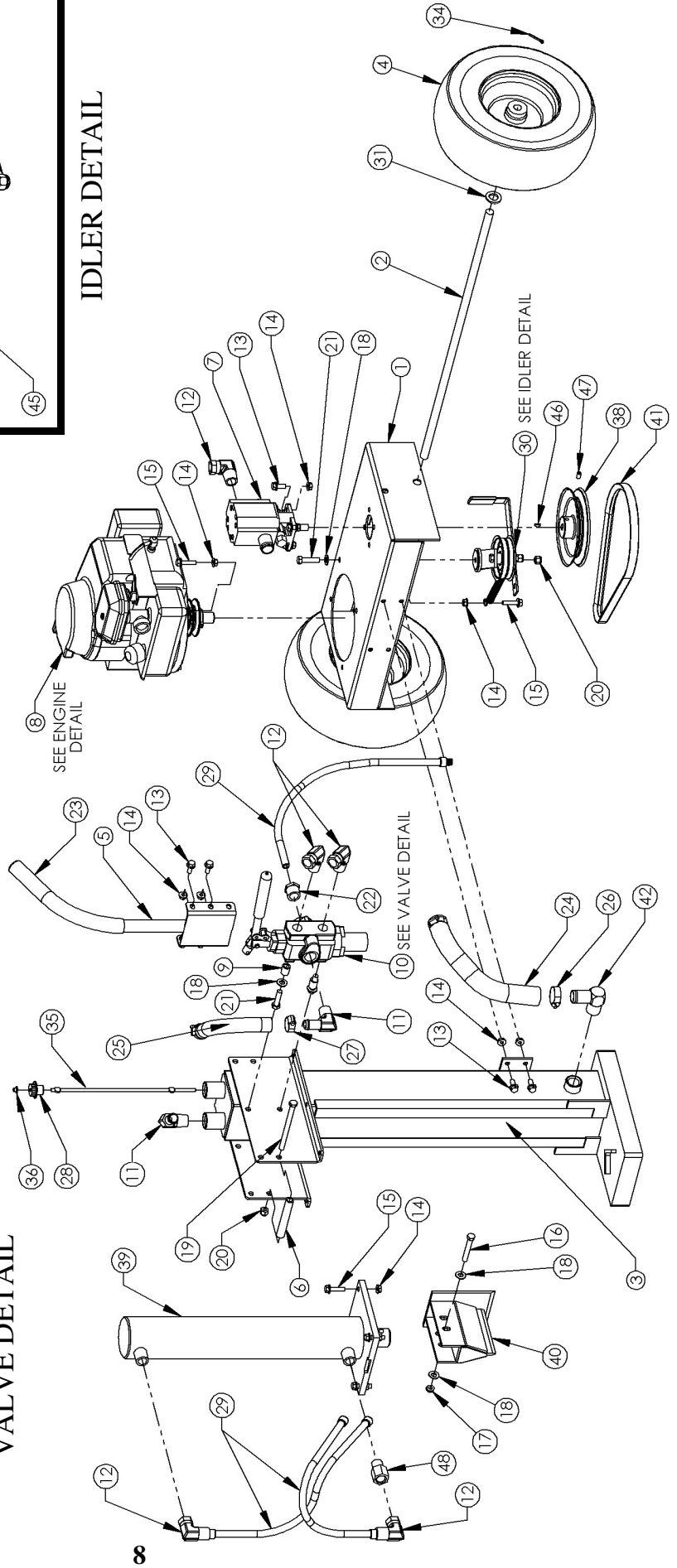

LS412 ASSEMBLY DETAIL

SERVICE PARTS

Please have Model and Serial Numbers ready when ordering parts.
Color cannot be guaranteed upon service parts.

ITEM NUMBER	DESCRIPTION	PART NUMBER
1	Motor Base Weldment Txt Blk	11551TK
2	Axle	11552
3	Beam Weldment Txt Blk	11533TK
4	Tire/Wheel - 5/8 Bearing 13x5x6 NHS	F4157W
5	Handle Weldment Txt Blk	11535TK
6	4" Spacer Txt Blk	11553TK
7	Hydraulic Pump 11 gpm	LS2001H
8	4HP B&S Engine	11400
8A	3" Engine Pulley	11398
8B	3/16 X 1 Key Stock	9030
8C	5/16-18 X 1/2 Set Screw With Loctite	NB312
8D	7/16 X 1 1/4 Belleville Washer	699
8E	3/8-24 X 1 Engine Bolt Locktite	NB238N
9	3/4" Spacer Txt Blk	11554TK
10	Valve Control Splitter Painted	7287TK
10A	Valve Handle	7423
10B	Valve Handle Grip	7425
10C	1/4 X 1 Clevis Pin	NB522
10D	3/32 X 3/4 Cotter Pin	NB597
10E	Master Link	7424
11	Fitting Return Line	7329
12	90 Degree Male Pipe Swivel Elbow	11557
13	5/16-18 X 3/4 Serrated Flng Bolt	NB596
14	5/16-18 Serrated Flng Nut	NB170
15	5/16-18 X 1 1/4 Serrated Flng Bolt	NB253
16	3/8-16 X 2 1/2 HCC GR5 ZP	NB221
17	3/8-16 Nylok Nut Jam	NB207
18	3/8 SAE Washer	NB272
19	3/8-16 X 5 HCC GR5 ZP	NB199
20	3/8-16 Nyloc Nut	NB182
21	3/8-16 X 1 1/2 HCC GR5 ZP	NB107
22	Hex Reducer Bushing	11558
23	Handle Grip	7826
24	15" Suction Hose	11560
25	9" Return Hose	11561
26	Hose Clamp No. 16	LS4999
27	Hose Clamp No. 12	LS5001
28	3/4" NPT Filler Cap	11562
29	24" Pressure Hose	11559
30	Idler Assembly	11564
30A	3/8-16 X 2 1/2 HTC GR5 ZP	NB619
30B	Idler Plate Txt Blk	11563
30C	Idler Pulley: OD - 3.25", ID - 3/8"	B527
30D	3/8 SAE Washer	NB272
30E	3/8-16 2-Way Lock Nut	NB280
31	3/4ID X 1 1/4OD 10 GA. Washer	NB184
32	3/8 X 1 1/2 Fender Washer	10177
33	Idler Bushing	6037
34	1/8 X 1 Cotter Pin	NB126
35	Dip Stick	11565
36	1/4 Pal Nut	NB304
37	Handle Grip, Pivot	2077
38	6" Pump Pulley	11550
39	3" Cylinder Txt Blk	11180TK
40	Wedge Weldment Txt Blk	11534TK
41	33" Belt For Engine	690
42	90 Degree Pipe Beaded Insert	11792
43	Clutch Lever Txt Black	11226TK
44	Wire Link For Idler Arm	BRS6H
45	Clutch Rod Spring	682S
46	Key Woodruff	024002
47	5/16-18 X 1/2 SSC With Loctite	NB312
48	1/2" NPTF Male to Female Pipe Adaptor	12128

SPECIFICATIONS

LS412	
Splitting Force	12 Tons
Engine	4 HP Briggs and Stratton Sprint
Splitting Position	Vertical
Cylinder Size	3" X 18"
Pump	2 Stage with Heavy Duty Bearings
Pump Specs	11 Gallons Per Minute
Valve	Auto Return
Drive System	Belt Drive with Clutch for Easy Starting
Hydraulic Fluid Capacity	9-10 Quarts
Maximum Log Length	19"
Tire Specs	13.00 X 5.00
Metal Fenders	No
Unit Weight	Lbs



OWNER'S MANUAL

MODEL NO. LS412

LOG SPLITTER

HOW TO ORDER REPAIR PARTS:

Each Log Splitter has its own serial number. Each engine has its own serial number. The serial number for the Log Splitter will be found on the right hand side of the hydraulic oil reservoir. The serial number for the engine will be found on the top of the blower fan housing.

All Log Splitter parts listed herein may be ordered directly from Swisher Mower & Machine Co. Inc., your nearest Swisher dealer, or from our website.

All engine parts may be ordered from the nearest dealer of the engine supplied with your log splitter. Parts subject to change without notice.

WHEN ORDERING PARTS, PLEASE HAVE THE FOLLOWING INFORMATION AVAILABLE:

- * PRODUCT – SWISHER LOG SPLITTER
- * SERIAL NUMBER - _____
- * MODEL NUMBER - _____
- * ENGINE MODEL NUMBER - _____
- TYPE - _____
- * PART NUMBER
- * PART DESCRIPTION

www.swisherinc.com
TELEPHONE - 1-800-222-8183
FAX - 1-660-747-8650

SWISHER MOWER & MACHINE CO. INC.
1602 CORPORATE DRIVE
WARRENSBURG, MO 64093

SWISHER MOWER & MACHINE CO. INC.