

# **SWISHER**



## **REPAIR MANUAL**

### **FINISH CUT**

### **44" & 60" TRAIL MOWERS**

**Swisher Mower Co  
Warrensburg, MO**

## LIMITED WARRANTY

The manufacturer's warranty to the original consumer purchaser is: This product is free from defects in materials and workmanship for a period of one (1) year from the date of purchase by the original consumer purchaser. We will repair or replace, at our discretion, parts found to be defective due to materials or workmanship. This warranty is subject to the following limitations and exclusions:

- 1) Engine Warranty                      All engines utilized on our products have a separate warranty extended to them by the individual engine manufacturer. Any engine service difficulty is the responsibility of the engine manufacturer and in no way is Swisher Mower Co., Inc. or its agents responsible for the engine warranty. The Briggs & Stratton Engine Service Hot-Line is 1-800-233-3723. The Tecumseh Engine Service Hot-Line is 1-800-558-5402.
  
- 2) Commercial Use                      The warranty period for this product used for commercial or rental is limited to ninety (90) days from the date of original purchase.
  
- 3) Limitations                              This warranty applies only to products which have been properly assembled, adjusted, and operated in accordance with the instructions contained within this manual. This warranty does not apply to any product of Swisher Mower Co., Inc., that has been subject to alteration, misuse, abuse, improper assembly or installation, shipping damage, or to normal wear of the product.
  
- 4) Exclusions                                Excluded from this warranty are normal wear, normal adjustments, and normal maintenance.

In the event you have a claim under this warranty, you must return the product to an authorized service dealer. All transportation charges, damage, or loss incurred during transportation of parts submitted for replacement or repair under this warranty shall be borne by the purchaser. Should you have any questions concerning this warranty, please contact us toll-free at 1-800-222-8183. The model number, serial number, date of purchase, and the name of the authorized Swisher dealer from whom you purchased the mower will be needed before any warranty claim can be processed.

## **TABLE OF CONTENTS**

1. If engine won't crank – T60
2. Wiring diagrams – T60
3. If engine won't crank – Polaris brand
4. Won't crank – Polaris brand (cont)
5. If PTO clutch will not engage – Polaris brand
6. Engine cranks but won't start
7. Identification of wiring
8. T44 – If engine won't crank
9. T44 – If engine won't crank (cont)
10. Starting problems on the recoil start T44
11. Engine electrical components
12. Belt replacement – T60
13. Belt and associated parts – T44
14. Repairing or replacing blade driver
15. Replacement parts – quick guide

# IF ENGINE WON'T CRANK\*\*\*T60

## ALWAYS CHECK FUSE FIRST

### TEST #1

Using a remote starter switch or a suitable device, make a connection between the large terminals on the solenoid. If engine does **not** crank!!!

- Battery may be weak or dead
- Starter may be bad
- Battery cables may have bad connections
- Do **not** go to Test #2 until this test gives results.

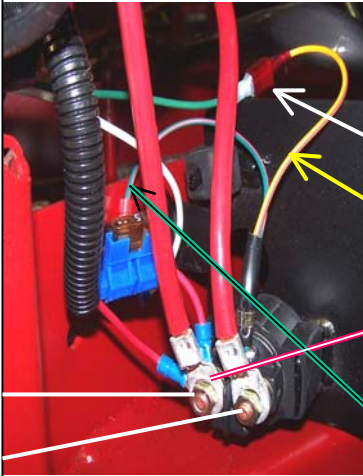

### TEST #2

If engine **did** crank in test #1, disconnect green wire at spade connector and apply positive voltage from the battery to the yellow wire with the orange stripe. The positive voltage can also be picked up on the solenoid terminal where the fuse connects. Make sure the green and black wire with the eyelet is well grounded. If engine doesn't crank now, replace the solenoid.

***Remember, all other tests are useless unless these two tests make the engine turn over.***



### TEST #3

If engine **did** crank in the first part of test #2, reconnect green wire to solenoid. Using a jumper wire attached to the positive terminal of the battery, apply 12 volts to the red wire on terminal **B** of the ignition switch. Try to crank, using the ignition switch. If engine cranks, the fuse or the fuse holder, or related wiring is defective somewhere back to the solenoid.

### TEST #4

If engine **did not** crank in test #3, this time move the jumper wire attached to the positive terminal of the battery, to the green wire on **S** terminal of the ignition switch. Ignition switch does have to be activated for this test. If engine cranks now, ignition switch needs replacing.

# WIRING DIAGRAMS

## BRIGGS 12V

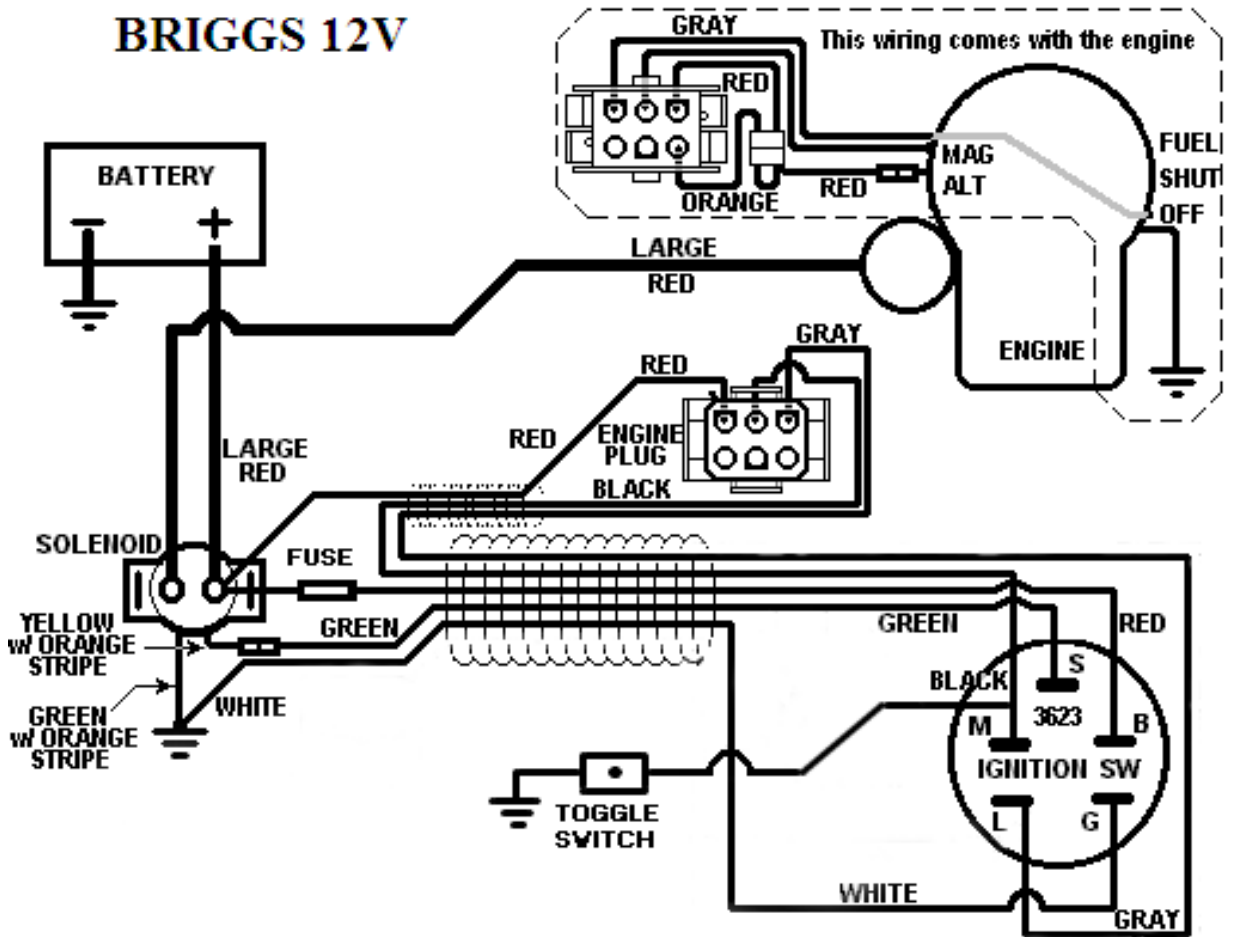

## KOHLER 12V

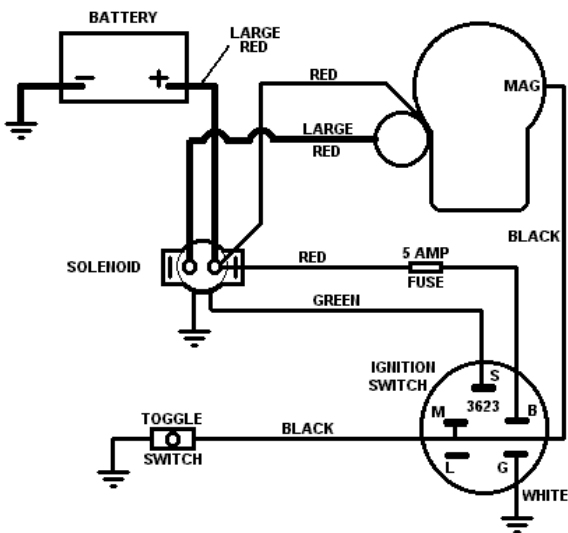

## HONDA 12V

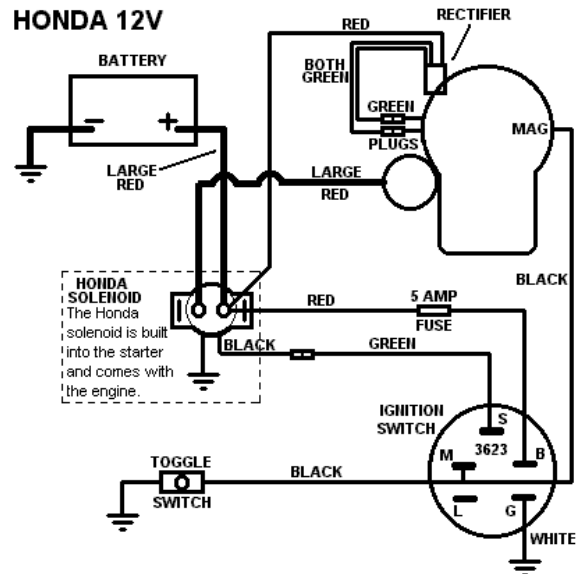

# IF ENGINE WON'T CRANK\*\*\*POLARIS BRAND

## ALWAYS CHECK FUSE FIRST

### TEST #1

Using a remote starter switch or a suitable device, make a connection between the large terminals on the solenoid. If engine does **not** crank!!!

- Battery may be weak or dead
- Starter may be bad
- Battery cables may have bad connections
- Do **not** go to Test #2 until this test gives results.

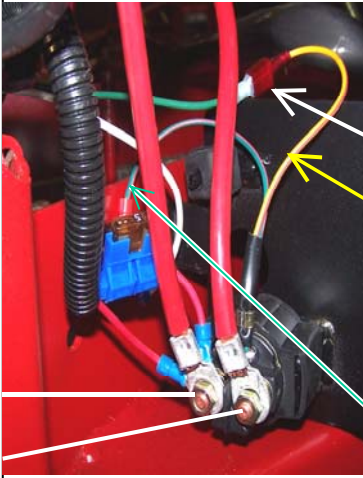

### TEST #2

If engine **did** crank in test #1, disconnect green wire at spade connector and apply positive voltage from the battery to the yellow wire with the orange stripe. The positive voltage can also be picked up on the solenoid terminal where the fuse connects. Make sure the green and black wire with the eyelet is well grounded. If engine doesn't crank now, replace the solenoid.

***Remember, all other tests are useless unless these two tests make the engine turn over.***



### TEST #3

If engine **did** crank in the first part of test #2, reconnect green wire to solenoid. Make sure the PTO switch is off. Using a jumper wire attached to the positive terminal of the battery, apply 12 volts to the red wire on terminal **B** of the ignition switch. Try to crank, using the ignition switch. If engine cranks, the fuse or the fuse holder, or related wiring is defective somewhere back to the solenoid.

### TEST #4

If engine **did not** crank in test #3, make sure the PTO switch is in the off position. This time move the jumper wire, attached to the positive terminal of the battery, to the green wire on the **S** terminal of the ignition switch. If all components in the circuit are working, the engine should crank. If it doesn't, move on to the next test.

# WON'T CRANK\*\*POLARIS BRAND (CONTINUED)

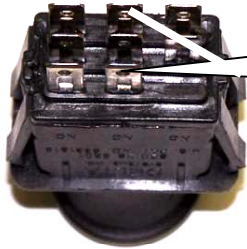

With PTO switch in the off position, meter should go to zero when checking continuity across these two terminals.

If the PTO switch tested bad, install a new one and perform **Test #4** again. If the switch is good, a connecting wire must be at fault. Check all connection on the green wire all the way back to the starter solenoid. Don't move past **Test #4** until it assures a good circuit. When you do get good results, hook all wires back to original position and try the ignition switch again. If no results, you will need to replace the ignition switch. Again remember, this is only after **Test #4** gives positive results.

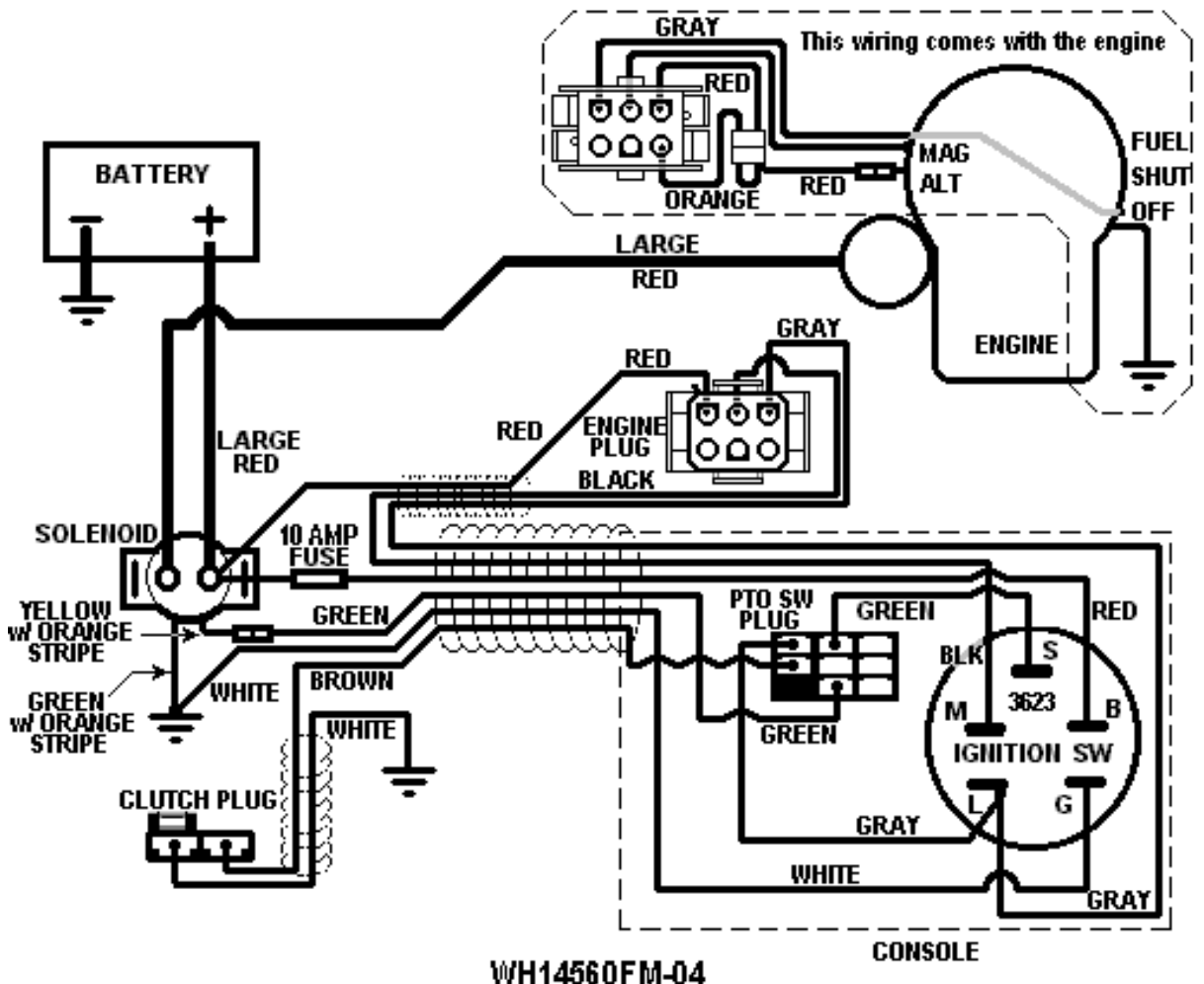

# IF PTO CLUTCH WILL NOT ENGAGE\*\*\*POLARIS BRAND



Apply a negative ground to this terminal

Apply 12 Volts to this terminal. Clutch should activate, if it doesn't, clutch is defective.

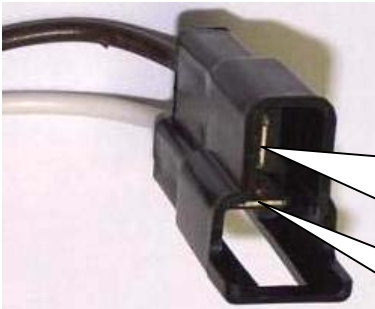

If clutch checks OK, use a voltmeter to measure for 12 volts at the brown wire's terminal. First turn ignition switch to the **ON** position but don't start the engine. Now engage the PTO switch. For the first test put the negative probe on a good ground, **not** on the white wire's terminal in the plug. If no voltage is measured, move on to next test.



The problem may be a poor ground on the white wire in the clutch plug. Check by testing for continuity to ground or check for voltage between the two terminals. If no voltage is measured, move on to next test.

Some of our clutches have a different receptacle for the wiring harness, but the testing is the same. The white wire is always the negative terminal and the brown wire is the positive.



With the PTO switch **ON** there should be continuity between these two connectors, if not, replace switch. If switch tested good, check wires and connectors back to ignition switch and back to clutch plug.

# ENGINE CRANKS BUT WON'T START

## Checks for electrical problems

- While turning ignition switch to its first position, listen for the fuel solenoid on the carburetor to click. It must click to supply fuel to the carburetor.
- Try a new spark plug.
- Check for spark at plug when it is removed and the threaded end is grounded.
- Unplug the six-position socket that connects engine wiring to mower wiring harness. Engine will still crank. If plug doesn't have a spark now, ignition module is probably defective.

## Checks for mechanical problems

- Make sure the tank gas valve is turned on.
- Remove air filter element to check for signs of gas in the throat of the carburetor.
- If no gas, check to see if choke is working properly.
- If all above checks show positive, carburetor must have an internal problem. Remove and clean the carburetor.

## ENGINE WIRING SYSTEM

Used on the T60

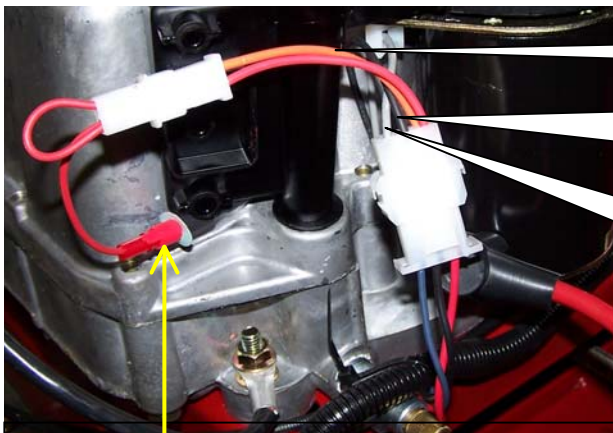

Orange is not used in this application

Black wire comes from the ignition switch and goes to the ignition module to shut engine off.

Gray wire goes to the fuel solenoid.

Red wire comes from engine's alternator through a diode to convert the voltage from AC to DC. A simple test to check its output is to measure the voltage of the battery before the engine is started. Now start the engine, the voltage should rise about 1 volt when the engine starts. This voltage will slowly drop back to normal voltage as the battery becomes fully charged.

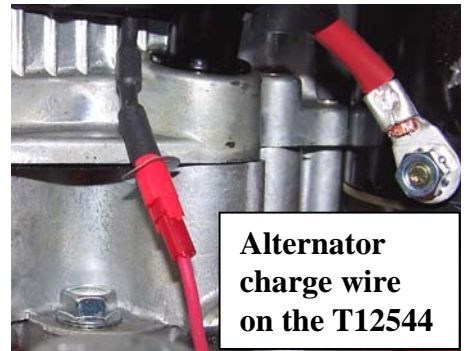

**Alternator charge wire on the T12544**

# IDENTIFICATION OF WIRING

## WIRING HARNESS AT STARTER SOLENOID

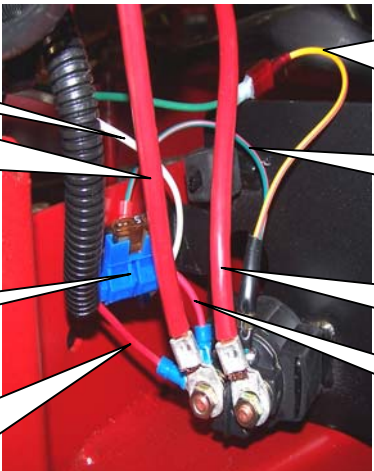

Grounded white wire goes back to the ignition switch.

Large red wire goes to the **positive** terminal of the battery.

In line 5 amp fuse.

Red wire goes to the engine plug and through to the alternator on the engine.

Yellow and orange wire from solenoid connects to the green wire that goes to the ignition switch.

Green and orange wire goes to chassis ground.

Large red wire goes to the engine starter.

Red wire goes through the fuse and on to the ignition switch.

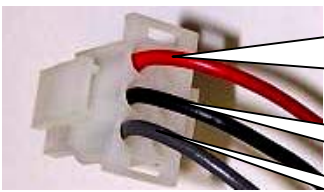

Red wire goes to the same terminal on solenoid as the positive battery cable.

Black wire goes to the ignition switch

Gray wire goes to the ignition switch.

**WIRING HARNESS PLUG TO ENGINE**

**NOTE**

Engine plug is used only on the Briggs engines. On the Honda and Kohler engines the red wire and black wire go directly to the engine. The gray wire is not used on the engines that have no fuel solenoid on the carburetor.

## WIRING HARNESS PLUG AT IGNITION

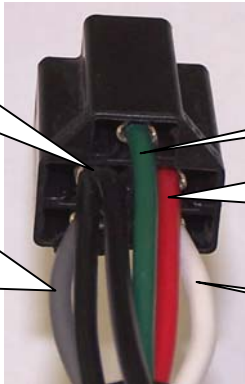

One black wire goes to the Toggle switch and the other goes to the engine plug

Gray wire goes to the fuel solenoid on the carburetor. Gray wire not used on the engines that have no fuel solenoid on the carburetor.

Green wire goes to the starter solenoid.

Red wire goes to the fuse and then on to the battery positive at the solenoid terminal.

White wire goes to chassis ground.



## T44\*\*\*IF ENGINE WON'T CRANK (CONTINUED)



A neutral switch is located on the right side in the belt housing. The plunger button must be depressed at least 3/8 inch when the blades are disengaged. This can be adjusted by loosening the two mounting screws and sliding the switch to the side. Ohmmeter should go to zero when checking continuity across switch terminals with plunger depressed.

After the switch has been adjusted and the continuity checked, or the switch replaced, perform **Test #4** again. If no results and the neutral switch is good, a connecting wire must be at fault. Don't move past **Test #4** until it assures a good circuit. When you do get good results, hook all wires back to original position and try the ignition switch again. If still no results, you will need to replace the ignition switch.

### BRIGGS & STRATTON 12V

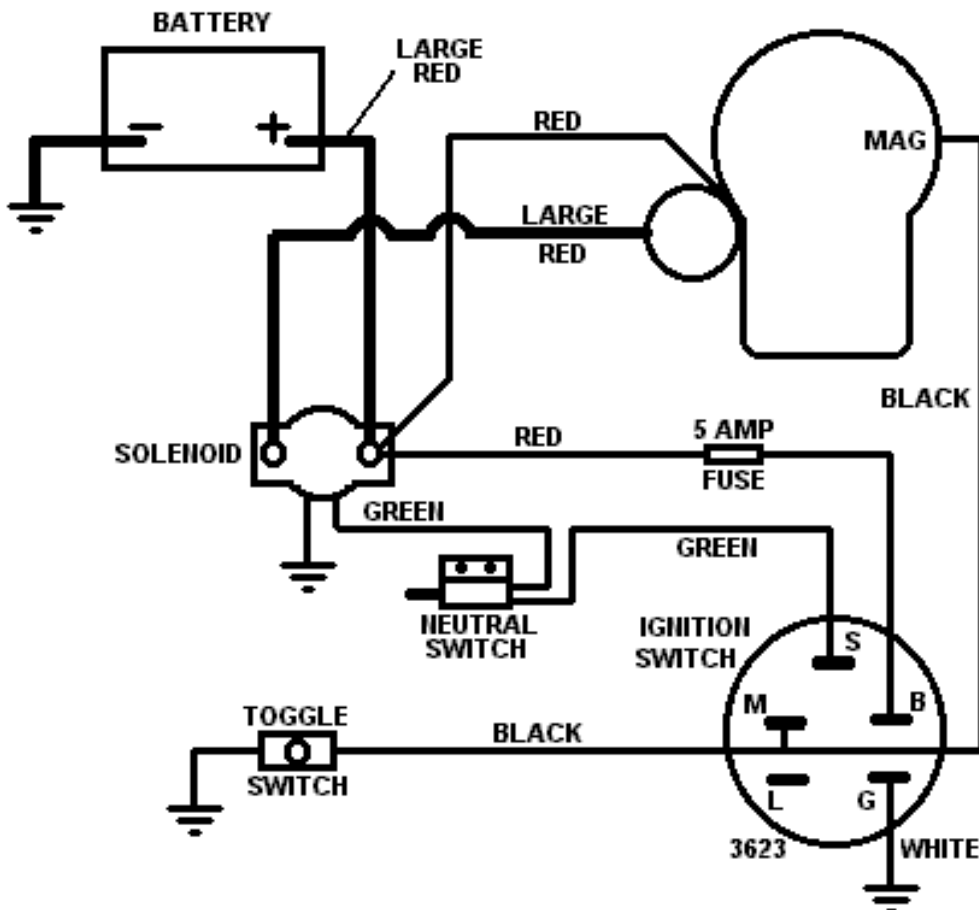

# STARTING PROBLEMS ON THE RECOIL START T44

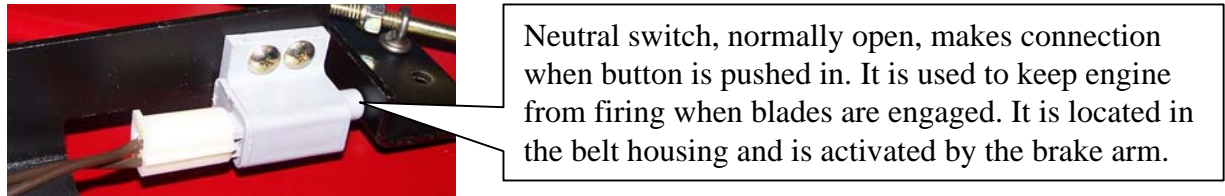
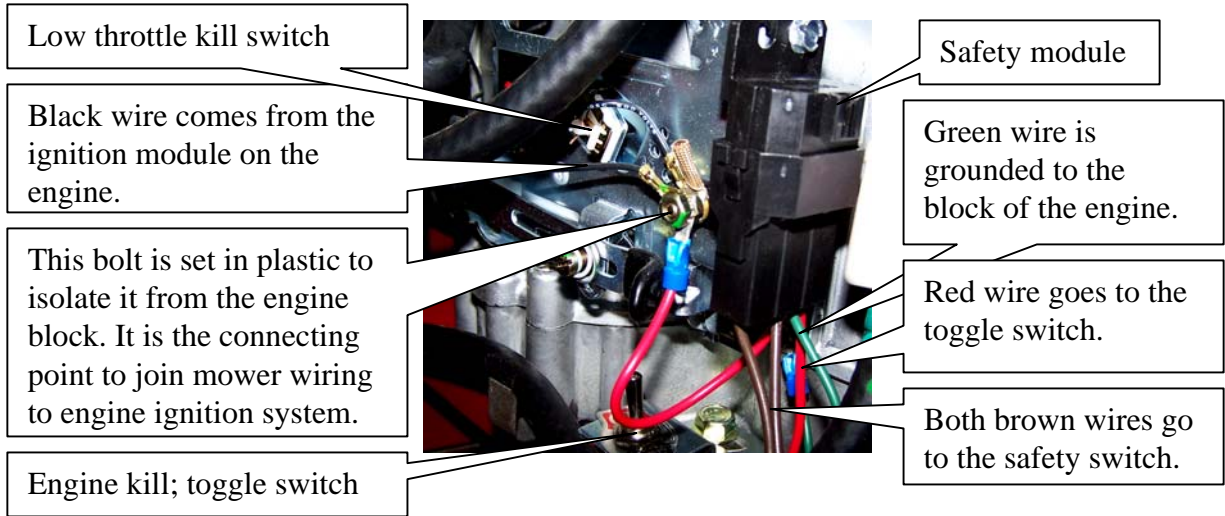

If the engine fails to start because of no fire at the plug start by removing the red wire from the connecting screw where it joins the black wire to the engine ignition. This will separate the engine from the mower's kill switches. Try to start the engine, if it won't fire now the ignition module is defective. If the engine does start it can still be shut down by lowering the throttle to its lowest setting. The most likely cause of not starting is the blade safety system. Don't just assume that the safety module is the defective. Remove the right cover on the belt housing and check the safety switch. The button has to be depressed at least 3/8 inch to make a short across the two brown wires to allow the safety module to work properly. The switch is adjustable to make this happen. Loosen the two small screws and slide the switch on its mount. Make sure nothing is restricting the movement of the brake arm.

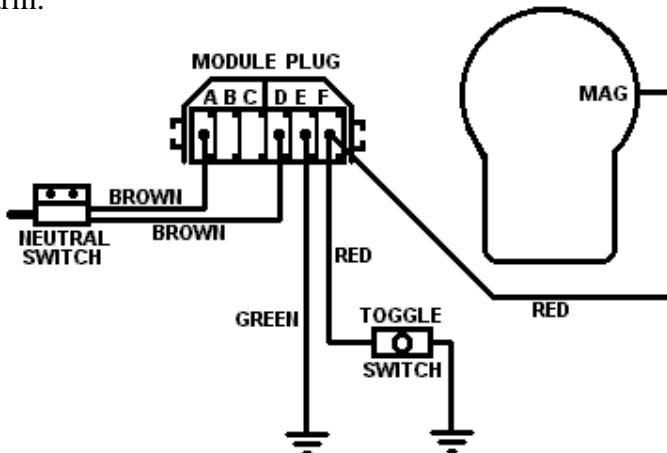

## CARBURETOR FUEL SOLENOID



Very thin 1/2" wrench needed to remove this solenoid. **Do not** try to remove by using a pair of pliers on the coil section. Coil can be damaged very easily.

Fuel shut off solenoid is a Briggs part and is available through them only.

Gray wire goes to the engine plug, then on to the ignition switch where it receives power to activate the fuel shut off valve.

Black wire goes to engine ground.

## SAFETY TOGGLE SWITCH



White wire is grounded to chassis.

Black wire is grounded to the chassis when the toggle switch is in **OFF** position. This black wire is connected to ignition module to kill the engine in an emergency if a tether is connected from toggle to the pulling vehicle.

## KILL WIRE CONNECTION POST

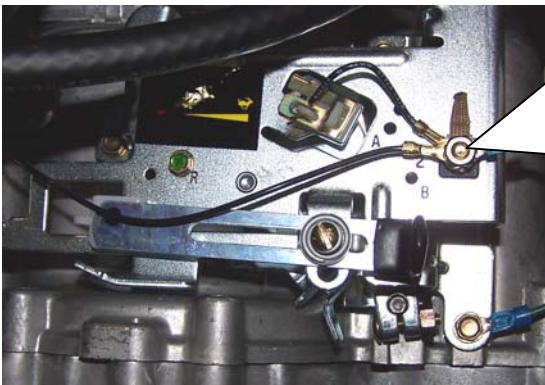

On most 12volt start Briggs engines without the standard 6 prong socket, and the recoil start models, a kill wire post is provided on the throttle plate. This is the point where manufacturers connect their ignition switches and safety kill switches. The engine wire that Briggs installs here goes to the ignition module above the cylinder and attaches to the spark plug. Shorting the ignition to ground is the only way to stop the engine.

# BELT REPLACEMENT\*\*\*T60



Front of engine mount

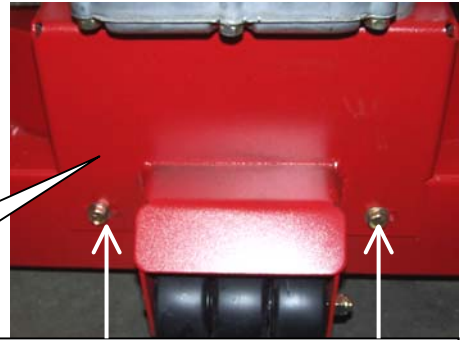

Rear of engine mount

Remove these 4 bolts to remove the engine mount from the deck for easier access to belts.



Notice the position of the belt guide. It is offset on the side next to the engaging idler. Belt will be quickly destroyed if guide is turned the other way.

The nut on this bolt should not be tight against the loop on the end of the spring. It needs to be able to rotate on the bolt.

This loop is where the return spring on the engaging idler is hooked.

Engine pulley

The nut on this bolt should not be tightened on the loop of the spring. There must be room to pivot.

Loosen this nut to relive tension on deck belt before replacing the belt.

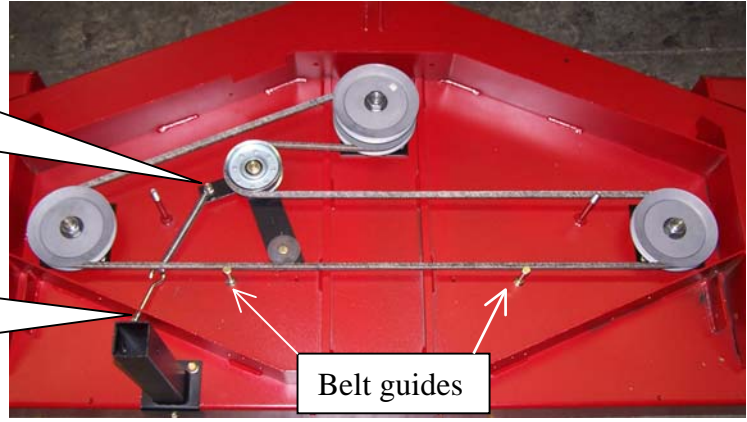

Belt guides

# BELT AND ASSOCIATED PARTS\*\*\*T44

The engine with it's mount can be removed for easy access to do major repairs. Just take out the two bolts in the front and two in the rear and lift it off.

Engine pulley is positioned here. Note routing of the belt.

Brake tension spring

Safety switch

Blade brake



## Belt guides

Always install belt with the guides on the back side of the belt.

Brake pad should contact both side of the pulley.

Adjust this nut to pull brake off before the pulley starts to turn, but make it loose enough to allow good brake contact on pulley when blades are disengaged.

Safety switch can be adjusted by loosening two bolt and sliding to the right to depress button at least 3/8 inch when blades are disengaged.



Belt can be tightened by turning the nuts clockwise on both sides or this angle bracket.

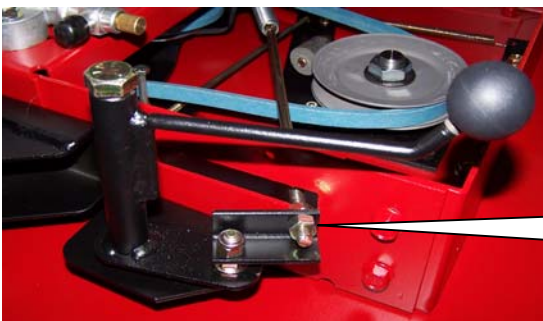

# REPAIRING OR REPLACING BLADE DRIVER

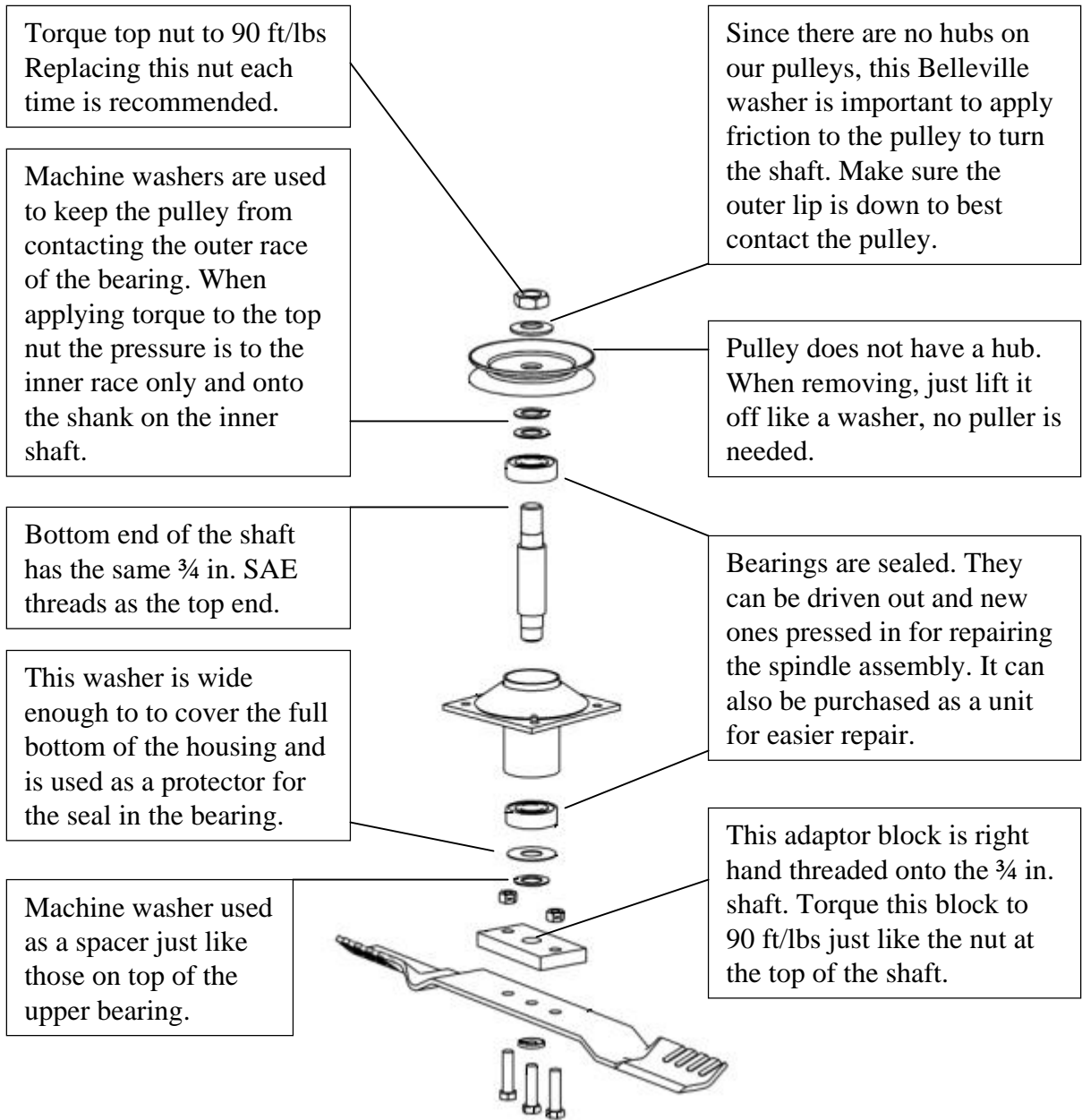

Install the blade adaptor block to the bottom of the shaft. Before applying torque, install the blade to the block using only the outer two bolts. Leave the center bolt out for now. Block the blade to outer deck edge by using a 4x4 or similar stop. Using a torque wrench on the top nut above the pulley, apply 90 ft/lbs. The top nut and the adaptor block will equally receive the tightening. Now put the washer on the center bolt and install into the shaft. Torque the three bolts to 35 ft/lbs. The center bolt will lock the block so it won't come off.

# REPLACEMENT PARTS

## Quick Reference

<u>Swisher Part#</u>	<u>Description</u>
<u>For T44</u>	
•4220	Belt
•9036	Set of blades
•B4104	Blade pulley
•9018	Blade driver assembly
•4582*	Fan hitch
•4583*	Hitch tube
<u>For T60</u>	
•6046	Engine to deck belt
•5058	Deck cross belt
•9037	Set of blades
•9058	Center blade driver assembly
•9018	Outer blade driver assembly
•6114	Blade pulley
•H7ASY	Height adjustment assembly
•10038	Eye bolt
•661*	Tongue hitch
•661A*	Solid stock hitch
<u>For both T44 &amp; T60</u>	
•9043	Starter solenoid
•3623	Ignition switch
•9008	Blade mount plate
•B527	Belt idler
•B19BLACK	Plastic knob

\* Used paint code: TC=RED, TK=BLACK

This manual was produced at the beginning of our 2006 production. It was specifically written for those models built after January, 2006. For those models built before that time refer to the owners manuals for specific parts or call the Swisher Mower factory for assistance.

For warranty issues or ordering parts for the engines or the hydro units, contact the authorized dealer in your area.

For additional assistance on service

Contact Swisher Mower Co., Inc.

Phone 1-800-222-8183

Fax 1-660-747-8650

E-mail [cust.serv@swisherinc.com](mailto:cust.serv@swisherinc.com)



swisherinc.com

## REPAIR MANUAL

## FINISH CUT TRAIL MOWERS



Each mower has its own model number. Each engine has its own model number. The model number for the T60 mower is found on the right side of the frame just above the rear wheel. On the T44 it is located on the right side of the belt housing, on the vertical portion. The model number for the engine will be found just behind the valve cover of the engine head.

All mower parts listed herein may be ordered directly from Swisher Mower & Machine Co. Inc. or your nearest Swisher dealer.

All engine parts may be ordered from the nearest dealer of the engine supplied with your mower.

WHEN ORDERING PARTS, PLEASE HAVE THE FOLLOWING INFORMATION AVAILABLE:

- \* PRODUCT
- \* SERIAL NUMBER - \_\_\_\_\_
- \* MODEL NUMBER - \_\_\_\_\_
- \* ENGINE MODEL NUMBER - \_\_\_\_\_  
TYPE - \_\_\_\_\_
- \* PART NUMBER WITH PAINT CODE
- \* PART DESCRIPTION

TELEPHONE - 1-800-222-8183

FAX - 1-660-747-8650

**SWISHER MOWER & MACHINE CO. INC.**

1602 CORPORATE DRIVE

P.O. BOX 67

WARRENSBURG, MO 64093



**SWISHER MOWER & MACHINE CO. INC.**