



swisherinc.com

OWNER'S MANUAL

STARTING SERIAL #:
L204-159001

MODEL NO.
POL10544C

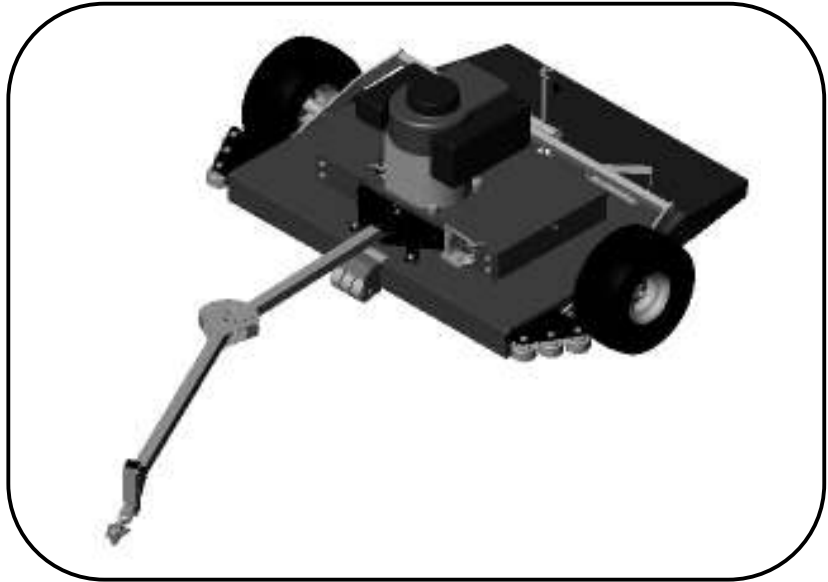

POLARIS 44" FINISH CUT TRAILMOWER

IMPORTANT
Read and follow all Safety
Precautions and
Instructions before
operating this equipment.

Rev. 05-041

**Assembly
Operation
Service and Adjustment
Repair Parts**

1602 CORPORATE DRIVE, WARRENSBURG, MISSOURI 64093 PHONE 660-747-8183
FAX 660-747-8650

Manufacturing quality lawn care equipment since 1945

Made In The

USA

LIMITED WARRANTY

The manufacturer's warranty to the original consumer purchaser is: This product is free from defects in materials and workmanship for a period of one (1) year from the date of purchase by the original consumer purchaser. We will repair or replace, at our discretion, parts found to be defective due to materials or workmanship. This warranty is subject to the following limitations and exclusions:

- 1) Engine Warranty all engines utilized on our products has a separate warranty extended to them by the individual engine manufacturer. Any engine service difficulty is the responsibility of the engine manufacturer and in no way is Swisher Mower Co., Inc. or its agents responsible for the engine warranty. The Briggs & Stratton Engine Service Hot-Line is 1-800-233-3723. The Tecumseh Engine Service Hot-Line is 1-800-558-5402.
- 2) Commercial Use the warranty period for any product used for commercial or rental is limited to ninety days from the date of original purchase.
- 3) Limitations this warranty applies only to products, which have been properly assembled, adjusted, and operated in accordance with the instructions contained within this manual. This warranty does not apply to any product of Swisher Mower Co., Inc., that has been subject to alteration, misuse, abuse, improper assembly or installation, shipping damage, or to normal wear of the product.
- 4) Exclusions excluded from this warranty are normal wear, normal adjustments, and normal maintenance.

In the event you have a claim under this warranty, you must return the product to an authorized service dealer. All transportation charges, damage, or loss incurred during transportation of parts submitted for replacement or repair under this warranty shall be borne by the purchaser. Should you have any questions concerning this warranty, please contact us toll-free at 1-800-222-8183. The model number, serial number, date of purchase, and the name of the authorized Swisher dealer from whom you purchased the mower will be needed before any warranty claim can be processed.

THIS WARRANTY DOES NOT APPLY TO ANY INCIDENTAL OR CONSEQUENTIAL DAMAGES AND ANY IMPLIED WARRANTIES ARE LIMITED TO THE SAME TIME PERIODS STATED HEREIN FOR ALL EXPRESSED WARRANTIES. Some states do not allow the limitation of consequential damages or limitations on how long an implied warranty may last, so the above limitations or exclusions may not apply to you. This warranty gives you specific legal rights and you may have other rights, which vary from state-to-state. This is a limited warranty as defined by the Magnuson-Moss Act of 1975.

SAFETY PRECAUTIONS



This Safety Alert Symbol indicates important messages in this manual. When you see this symbol, carefully read the message that follows and be alert to the possibility of personal injury.

Read this manual completely. This machine can amputate hands, feet, and throw objects. Failure to observe the following safety instructions could result in serious injury or death.

- Read the manual. Learn to operate this machine safely.
 - Always disconnect the spark plug wire and place the wire where it cannot contact the spark plug, to prevent accidental starting of the engine when setting up, transporting, adjusting or making repairs.
 - Keep all shields and guards in place.
 - Understand the speed, steering and stability of this machine. Know the positions and operations of all controls before you operate this machine. Check all of the controls in a safe area before starting to work with this machine.
 - Allow only responsible adults who are familiar with these instructions to operate this machine. Never allow children to operate this machine.
 - Clear the area of objects such as rocks, toys, wire, etc. that can be picked up and thrown by the blade.
 - Be sure the area is clear of other people before mowing. Be aware of the mower discharge direction and do not point at anyone. Stop the machine if anyone enters the mowing area. Children are often attracted to the machine and the mowing activity. ***Never assume that children will remain where you last saw them.*** Keep children under the watchful care of another responsible adult.
- No riders!**
- Do not put hands or feet near or under rotating parts. Keep clear of the discharge opening at all times.
 - Do not mow in reverse. Always look down and behind before and while backing.

- Turn off the blades when not mowing. Before leaving the machine, turn off the blades and stop the engine.
- Watch for traffic when operating near or crossing roadways.
- Do not operate the mower if it has been dropped or damaged in any manner or if the mower vibrates excessively. Excessive vibration is an indication of damage. Repair mower as necessary.
- Dress properly. Do not operate the mower when barefoot or wearing open sandals. Wear only solid shoes with good traction when mowing.
- Do not operate the machine while under the influence of alcohol or drugs.
- Operate self-propelled machines up and down slopes. There is significant risk of overturns when operating across slopes. Operate walk-behind machines across slopes. There is a significant risk of slipping under a walk-behind machine when operating up and down slopes. Do not operate on slopes greater than 15 degrees.
- Never tamper with safety devices. Check their proper operation regularly.
- Stop and inspect the equipment if you strike an object. Repair, if necessary, before restarting.
- Never make adjustments or repairs with the engine running.
- Mower blades are sharp and can cut. Wrap the blades or wear gloves, and use extra caution when servicing them.



SAFETY DECALS

Replace decal immediately if damaged. Order by part number from Swisher Mower and Machine Co. Inc.



OD55-Triangle Danger Decal
(All four deck corners)



OD33-Speed Decal

TrailMower Serial #

OD99127-44" Deck White Decal
(Not Pictured)

OD99127-44" Deck White Decal
(Not Pictured)

Engine Serial #



OD15-Void Warranty Decal



OD36-Deflector Decal



OD11-No Step Decal



OD29-Danger Decal

OD75-Polaris Decal
(Not Pictured)



OD45-Warning Decal

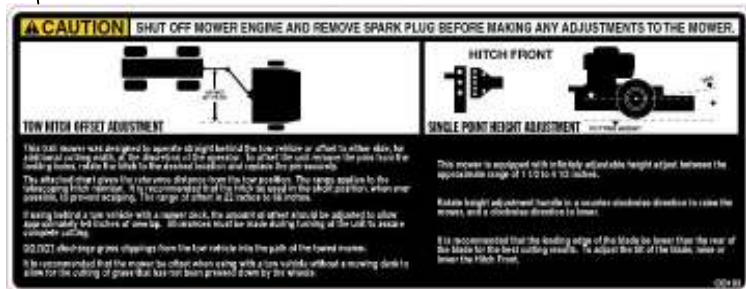

OD103-Single Point Height Adjust Decal

OPERATING YOUR TRAILMOWER



The operation of any mower can produce foreign objects to be thrown into the eyes, resulting in severe eye damage. Always wear certified safety glasses or wide-vision safety goggles over spectacles before starting any cutting machine and while operating such a machine.



The operation of any cutter produces sound waves that are damaging to the human ear. Ear protection is recommended.



CAUTION!

Tragic accidents can occur if the operator is not alert to the presence of children. Children are often attracted to the machine and the mowing activity. *Never assume that children will remain where you last saw them.*

INTENDED USE

The 44" TrailMower is designed to produce a quality finish cut on lawns, golf courses, etc. It is not intended to clear brush or cut saplings. Your TrailMower should be towed behind an ATV, golf cart, lawn tractor, or other approved vehicle. It is not designed for speeds exceeding 5 MPH. **WARNING:** To avoid serious injury, operate your mower up and down the face of slopes, NEVER across the face. **DO NOT MOW SLOPES GREATER THAN 15 DEGREES!** (See attached guide for sighting slopes.)

ATTACHING TRAILMOWER TO TOW VEHICLE

- Back vehicle up to desired towing position.
- Offset the TrailMower to the side opposite the tow vehicle discharge (if any). This prevents the tow vehicle from throwing grass into TrailMower engine.
- Bolt swivel hitch (H10) to tow vehicle receiver. If tow vehicle has a ball hitch, the ball must be removed before swivel hitch can be fastened.
- Attach tow hitch (4582) to the swivel hitch with hitch pin (H11). Make certain the hitch pin goes completely through each piece and is clipped to prevent accidental separation. (FIGURE FOUR)
- Securely attach safety tether (6736) to tow vehicle and to the TrailMower toggle switch located on right side of the engine. The safety tether will stop the TrailMower engine either manually or if the two should become separated. **It is very important that the safety tether is securely attached to both the toggle switch and to the tow vehicle.** (FIGURE TWO)

TRANSPORTING MOWER

- Stop TrailMower.
- Place TrailMower deck in its highest position.
- When transporting unattached from tow vehicle, remove spark plug wire and place it where it cannot contact the spark plug.

ENGAGING BLADES (without T-handle option, Standard)

The TrailMower will not start if the blade lever is in the “ENGAGED” position.

- Engage blades by rotating blade lever into the “ENGAGED” position.
- Rotate blade lever in opposite direction to disengage blade.
- The dual braking system is applied when the blades become disengaged. It is designed to bring the blades to quick stop (approximately 7 seconds). Each TrailMower brake system has been tested and calibrated. For safety, the consumer should not alter the braking system.

ENGAGING BLADES (with T-handle option, for order information see detail)

The TrailMower will not start if the T-handle console is in the “ENGAGED” position.

- Engage blades by pulling T-handle lever into its horizontal position.
- Return lever to its vertical position to disengage blades.
- The dual braking system is applied when the blades become disengaged. It is designed to bring the blades to quick stop (approximately 7 seconds). Each TrailMower brake system has been tested and calibrated. For safety, the consumer should not alter the braking system.

STARTING THE ENGINE

See engine manufacturer’s recommendations for the type and amount of oil and fuel used. Trail Mowers equipped with an electric start engine will need a battery (sold separately). Swisher recommends using a standard “12N12A” battery.

- Make sure the tow vehicle parking brake is set, mower is level, and blades are disengaged. Engine must be level to accurately check and fill oil. Do not overfill.
- Check spark plug wire, oil, and fuel.
- Check all electrical connections for build-up or debris.
- Make sure toggle switch is not turned “OFF” and safety tether is attached.
- Set engine idle to “CHOKE” position.
- With feet clear of mower deck, turn key switch to the “START” position; release when engine begins to run (12volt models). Recoil models must use pull-rope. Pull rope with a single fluid motion.
- Set engine throttle at maximum RPM.
- Allow engine to run a few moments before engaging blades.

BREAKING IN YOUR MOWER

- Set vehicle parking brake or chock wheels to prevent accidental rolling.
- Start engine properly.
- Slowly, engage blade control.
- In a safe environment, i.e. no children, allow blades to rotate and engine to idle for 5 minutes. This breaks in the belts and the engine.
- Stop mower properly.



CAUTION!

SHUT OFF MOWER ENGINE AND REMOVE SPARK PLUG WIRE FROM SPARK PLUG BEFORE MAKING ANY ADJUSTMENTS TO THE MOWER.

MOWER HEIGHT ADJUSTMENT

- Make adjustments while TrailMower is not running.
- There is approximately 1 ½” to 4 ½” of height adjustment.
- Rotate height adjust crank handle in a counter-clockwise direction to lift the mower deck. A clockwise direction is used to lower the mower deck.
- For best results, see “SUGGESTED PRACTICE” section. Graduated scales are for reference only, not the actual cutter height.

FRONT TO BACK ADJUSTMENT

For best cutting results, the mowing deck should be raised to ¾” higher in the rear.

- Make adjustments while TrailMower is not running.
- Remove bolts from the “L” hitch (H1), (SEE FIGURE FOUR).
- Raise or lower hitch section to obtain proper front to back adjustment.
- Re-install bolts in “L” hitch securely.

TOW HITCH OFFSET

This TrailMower has been designed to operate offset from the center of the tow vehicle or consecutively with another TrailMower, providing additional cutting width. When offsetting the mower do so to the side opposite the discharge of the tow vehicle.

- Swisher recommends if the tow vehicle is equipped with a mid-mount mower to overlap the cut approximately 6”. This may vary depending on mowing terrain, obstacles, and/or tow vehicle. Always keep SAFETY the first priority.
- If the tow vehicle is not equipped with a mid-mount mower, we still recommend offsetting the mower so that the tow vehicle does not crush the grass.
- To change the offsetting position both ball-lock pins should be removed (Figure One). The hitches will swivel around remaining bolts. Set hitches to desired positions and return ball-lock pins, making sure they go thru the hitch tubing and the semi-circled hole patterned plates.

STARTING TO MOW

- Adjust the cutting height.
- Double check vehicle to mower attachment.
- Start mower engine and set throttle to “FAST” for best cutting performance.
- Slowly engage blade clutch lever.
- Carefully mount vehicle and start mowing at a slow travel speed.

STOPPING THE MOWING SESSION

- Bring tow vehicle to a complete stop, shut off engine, and set parking brake.
- Disengage blades.
- Manually shut toggle switch and/or key switch to their “OFF” positions.
- Always remember to remove keys to avoid irresponsible usage.

SUGGESTED MOWING PRACTICES

- Operate mower engine at full throttle to assure the best cutting performance and maximum material discharge.
- Allow wet grass to dry. Wet grass will clump and collect under the mowing deck.
- Mowing should be started with tow vehicle in low gear and increased only as safe mowing conditions permit. Mowing speed should not exceed 5 MPH.
- The average lawn should be cut to approximately 2.5" during the cool season and to over 3" during the hot months.
- For a healthier lawn and better aesthetics, your lawn should be mowed often and after moderate growth.
- When cutting high or dense grass areas go slowly. Some areas may need to be mowed twice. The second cut should be at 90 degrees to the first, if possible.
- **Mowing thick or high grass:** Raise front of deck to ½" to ¾" above rear of deck. See "FRONT TO BACK ADJUSTMENT". When mowing thick or high grass, it is recommended to cut area twice. The first at a higher setting and the second at the desired lawn height.
- **Creating a manicured lawn:** Never cut more than 1/3 of the grass height in one cutting.

GENERAL TROUBLE SHOOTING

The mower is not cutting level.

- Check air pressure of all tires; make sure they are equal. See tires for maximum inflation.
- Make certain blades are installed identical, without the engine running.

The engine will not start.

- Disengage blades, turn toggle switch to "OFF" position, check battery and all other electrical connections, and inspect spark plug and wire (FIGURE THREE).
- Contact engine manufacturer or qualified mechanic.

Engine runs poorly.

- See engine manual.
- Check the throttle adjuster.
- Replace fuel, clean fuel filter and fuel line.
- Check spark plug and gap.

Mower bounces excessively while towing.

- Lower tire pressure.
- Tow at a slower speed.



IF PROBLEMS PERSIST HAVE A QUALIFIED MECHANIC SERVICE THE MOWER. NEVER ATTEMPT TO MAKE AN ADJUSTMENT THAT YOU ARE NOT SURE IS CORRECT. DOING SO CAN CAUSE OTHER PROBLEMS.

MOWER MAINTENANCE

GENERAL RECOMMENDATIONS

The warranty on this TrailMower does not cover items that have been subjected to operator abuse or negligence. To receive full value from the warranty, operator must maintain unit as instructed in this manual.

Some adjustments will need to be made periodically to maintain your unit properly. All adjustments in this manual should be checked at least once each season.

BEFORE EACH USE

- Check engine oil level on a level surface. (Check twice to insure an accurate reading.)
- Check condition of air filter; clean and replace as necessary.
- Check blade operation; keep blades in good condition.
- Check for loose fasteners and tighten them as needed.

AFTER EACH USE

- Keep blades sharp.
- Remove fresh grass clippings with garden hose.
- Hardened grass clippings on underside should be scraped out with a putty knife.
- Keep fluids at proper levels.
- Cover unit to prevent rain or other debris build-up. Definitely cover the engine.

BEFORE AND/OR AFTER EACH SEASON

- Replace the spark plug.
- Clean or replace the air filter.
- A new spark plug and clean air filter assure proper air-fuel mixture and help your engine run better and last longer.
- Check blades and belts for wear. Replace as necessary.
- Change the oil.
- See engine manufacturer's recommendations for servicing.

STORAGE RECOMMENDATIONS

⚠ CAUTION! Do not store engine indoors or other poorly ventilated area. Keep engine away from gas appliances and water heaters where fumes could contact open flame, pilot lights, or sparks.

If engine is to be stored for 30 or more days, prepare unit as follows:

- Drain fuel outside into an approved container.
- Start engine properly and run until unit is out of fuel.
- Let engine cool.
- Remove remaining gasoline from carburetor and fuel tank to prevent gum deposits from forming within the engine. Gum deposits can cause malfunction in the engine.
- Store mower with blades disengaged to prevent belts from being permanently stretched.

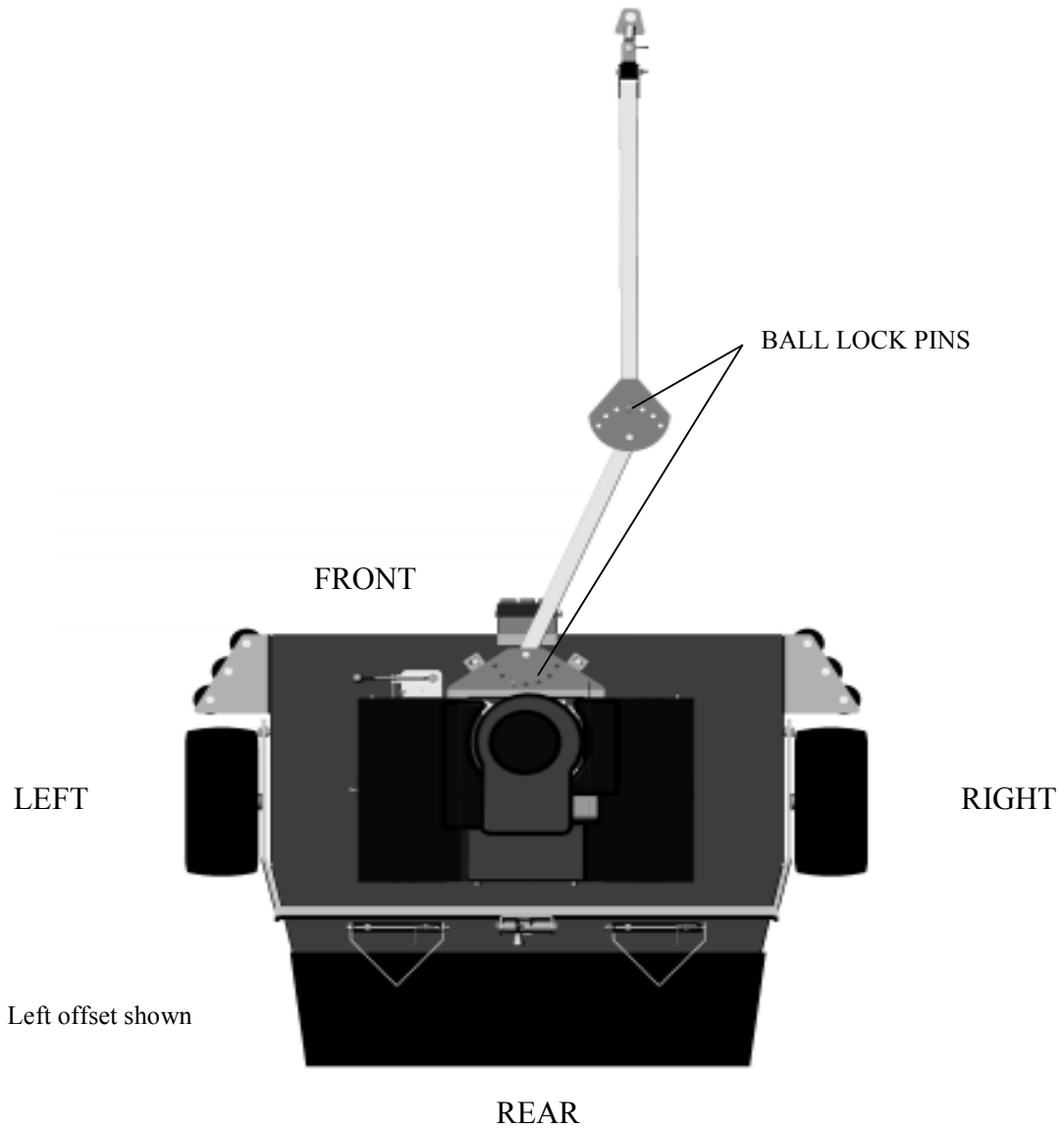

FIGURE ONE

Slide plastic tube snug against toggle switch.

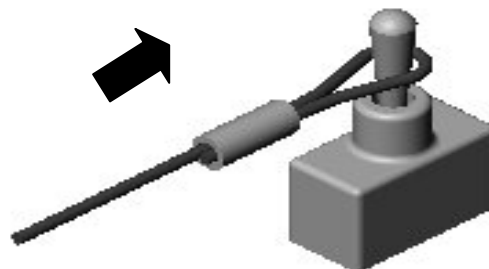
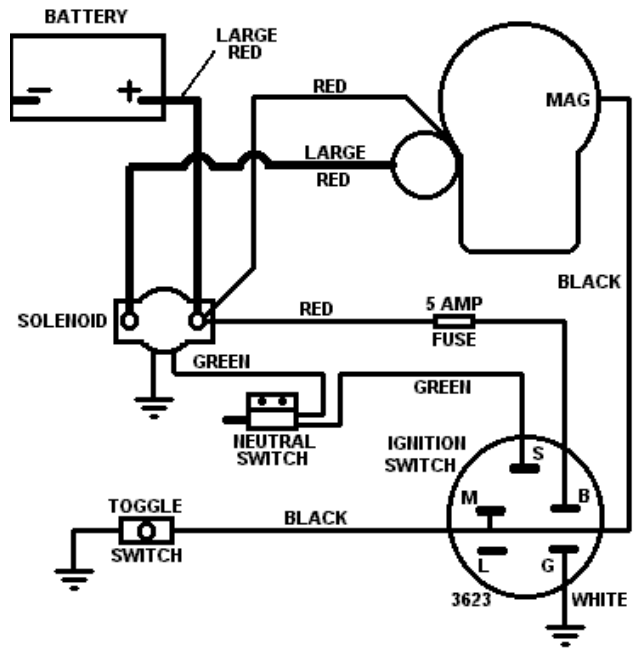

FIGURE TWO
(FIGURE FIVE FOR DETAILS)



T44 RECOIL START



T44 12 VOLT START

FIGURE THREE
WIRING CONFIGURATIONS

PARTS NOT SHOWN

WIRING HARNESSES	
B&S ENGINE (Remote Start only)	WH44CHB12V
HONDA ENGINE	WH1144H
REMOTE OPTION (Recoil Start)	WH44RCH
PULL START W/ B&S ENGINE	10638
TOGGLE/GROUND WIRE ASSEMBLY	9090
BLADE ENGAGE CABLE	9074
12V B&S MANUAL BLADE ENGAGE	10235
12 VOLT MODELS	
BATTERY (12N12A) RECOMMENDED	SOLD SEPARATELY
SOLENOID	9043
BATTERY CABLE - POSITIVE	BCSR
BATTERY CABLE - NEGATIVE	BCS
EXTRAS	
VELCRO STRAPS	7033
SWISHER DECAL	OD99125
44" DECAL	OD99127
INTERLOCK MODULE	MOD1
BATTERY BOX	4609TK
BATTERY PAD	BATPAD
BATTERY CABLE	BCL
BATTERY BOOT	BCBT
BATTERY HOLD DOWN	BHOLD

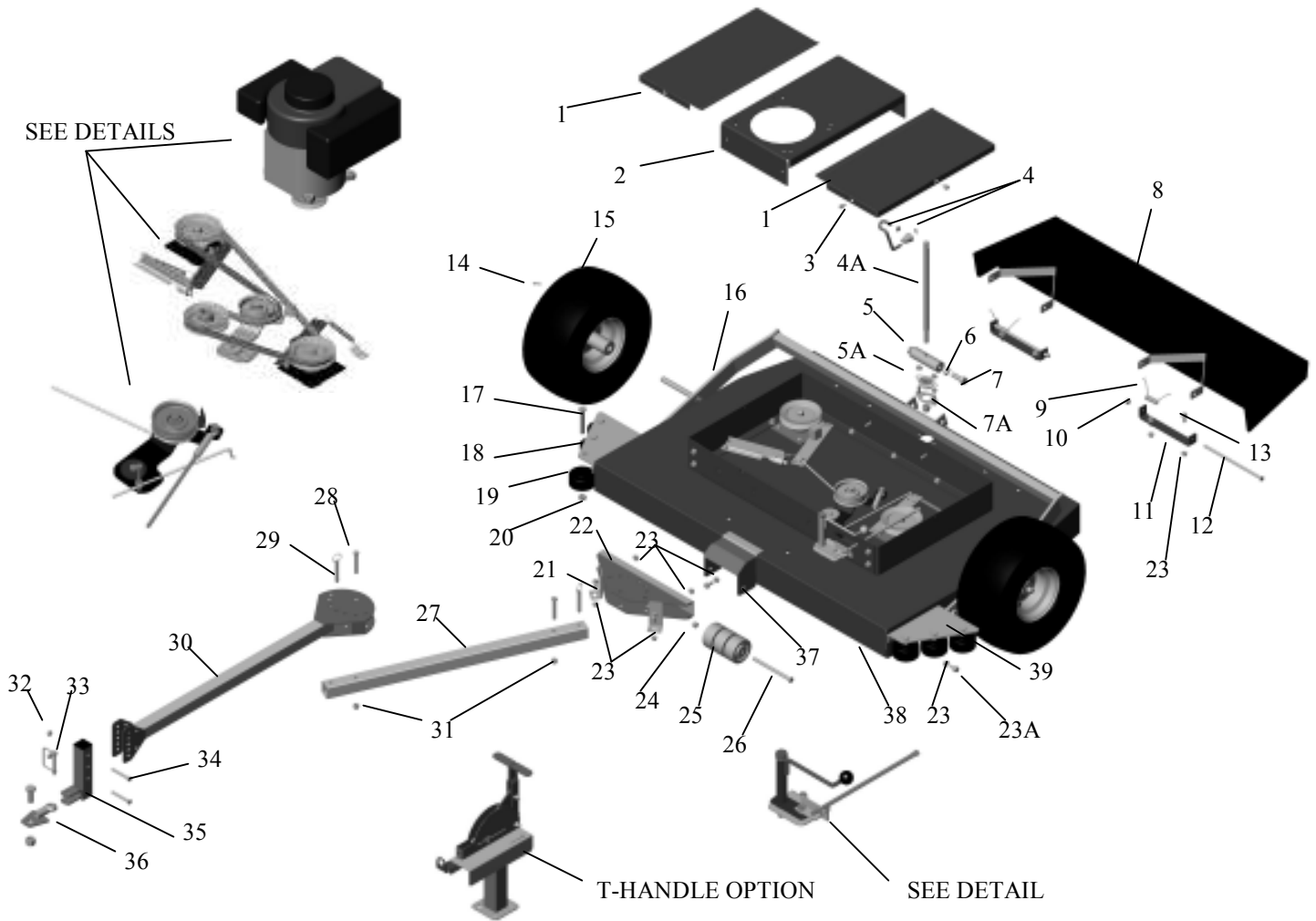

FIGURE FOUR
SINGLE POINT HEIGHT ADJUST

ITEM #	DESCRIPTION	PART #
1	BELT COVER	4524*
2	MOTOR BASE	4517*
3	1/4 BOLT	NB114
4	HEIGHT ADJUSTER	
	KNOB	H7K
	5/16 PAL NUT	NB276
	5/16 PUSH NUT	NB117
	ARM	ES214
4A	HEIGHT ADJUST ROD	4006
5	PIVOT BLOCK	4007TK
5A	FLANGE BEARING	4005
6	1/2 BUSHING	NB177
7	1/2 BOLT	NB617
7A	BEARING CAP	4036TK
8	DISCHARGE CHUTE	4585TK
9	TORSION SPRING	9100
10	5/16 NUT	NB181
11	CHUTE MOUNT	6030TK
12	5/16 BOLT	NB136
13	5/16 BOLT	NB596
14	COTTER PIN	NB126
15	TIRE/WHEEL	F44157LV
16	AXLE ASSEMBLY	4040TK
17A	1/2 BOLT	NB588
17B	1/2 NUT	NB118

ITEM #	DESCRIPTION	PART #
18	RIGHT ROLLER BRACKET	4016TK
19	ANTI-SCALP ROLLER 1/2"	AS003
20	1/2 NUT	NB121
21	5/16 BOLT	NB596
22	HITCH	4525TK
23	5/16 NUT	NB170
23A	5/16 BOLT	NB596
24	3/8 NUT	NB182
25	ANTI-SCALP ROLLER 3/8"	AS001
26	3/8 BOLT	NB575
27	HITCH TUBE	4583*
28	3/8 BOLT	NB221
29	3/8 LOCK PIN	NB520
30	FAN HITCH	4582*
31	3/8 NUT	NB182
32	5/16 NUT	NB181
33	SAFETY HITCH PIN	H11
34	5/16 BOLT	NB138
35	L HITCH	H1TK
36	SWIVEL HITCH	H10TK
	BOLT/NUT	NB145Z/NB561
37	ROLLER BRACKET	4018TK
38	DECK WELDMENT	4587*
39	LEFT ROLLER BRACKET	4015TK
	FRONT SKIRT PLATE	4518*
	BACK SKIRT PLATE	4519*
	SKIRT PLATE-BOLT/NUT	NB596/NB170

* = USE PAINT CODE: EX: 4524RTC; 4525G
TC=RED,G=GREEN;S=SILVER,TK=BLACK

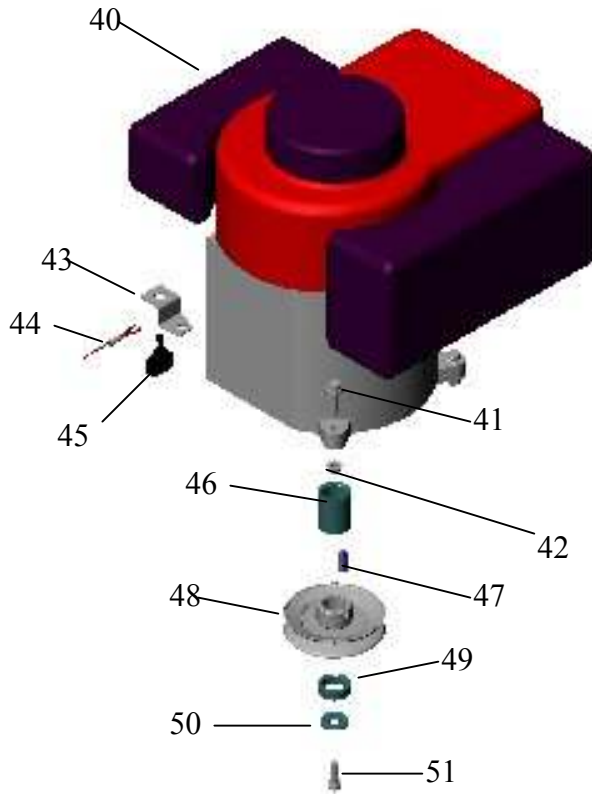
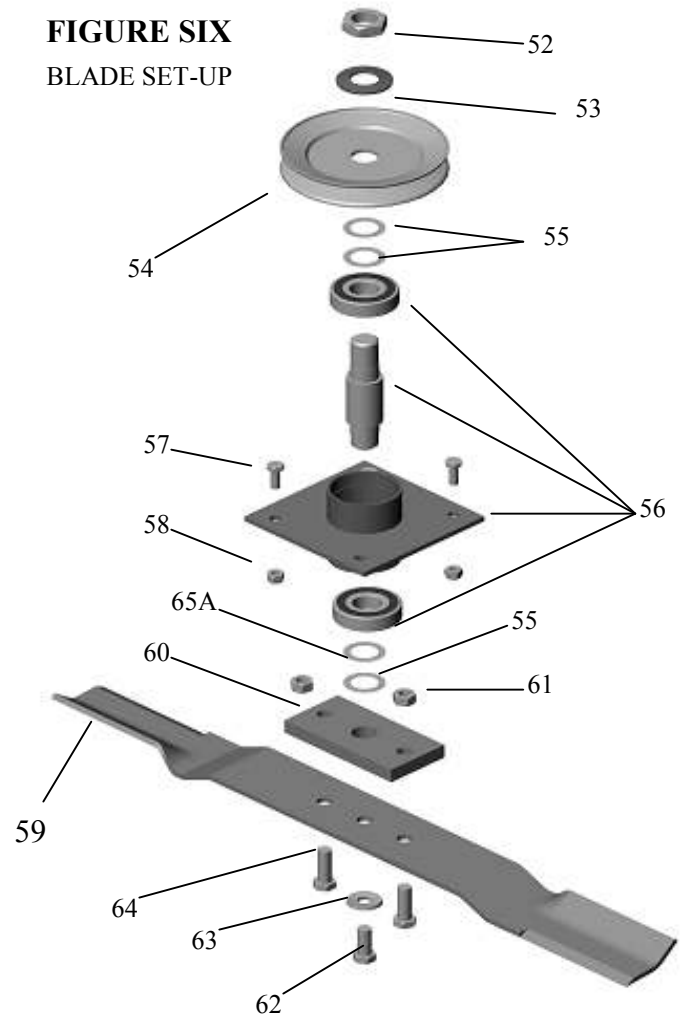

FIGURE FIVE
ENGINE SET-UP

ITEM #	DESCRIPTION	PART #
40	ENGINE	NOT AVAILABLE
41	5/16 BOLT	NB253
42	5/16 NUT	NB170
43	TOGGLE BRACKET	4483Z
44	SAFETY TETHER	6736
45	TOGGLE SWITCH	685SP
46	UPPER ENG. SPACER	BB105S
47	1/4 X 1 KEY STOCK	9031
48	ENG. PULLEY	BB105
49	LOWER ENG. SPACER	BB105SL
50	BELLEVILLE WASHER	699
51	7/16 BOLT	NB452N
	OIL DRAIN VALVE & CAP	AS122/AS123
	MODULE & SCREW	MOD1/NB137

FIGURE SIX
BLADE SET-UP



ITEM #	DESCRIPTION	PART #
52	3/4 NUT	NB175
53	UPPER BELLEVILLE	AS155
54	BLADE PULLEY	B4104
55	THIN WASHER	NB179
56	BLADE DRIVER	9018
	BEARING	B98
	4.25" SHAFT	9076
	BEARING HOUSING	B99ECTK
57	1/4 BOLT	NB250
58	1/4 NUT	NB180
59	22" BLADE	9005
	Two Blade Set	9036
60	BLADE MOUNT PLATE	9008
61	3/8 NUT	NB216
62	3/8 BOLT	NB238N
63	LOWER BELLEVILLE	NB607
64	3/8 BOLT	NB238
65A	WASHER	B98W

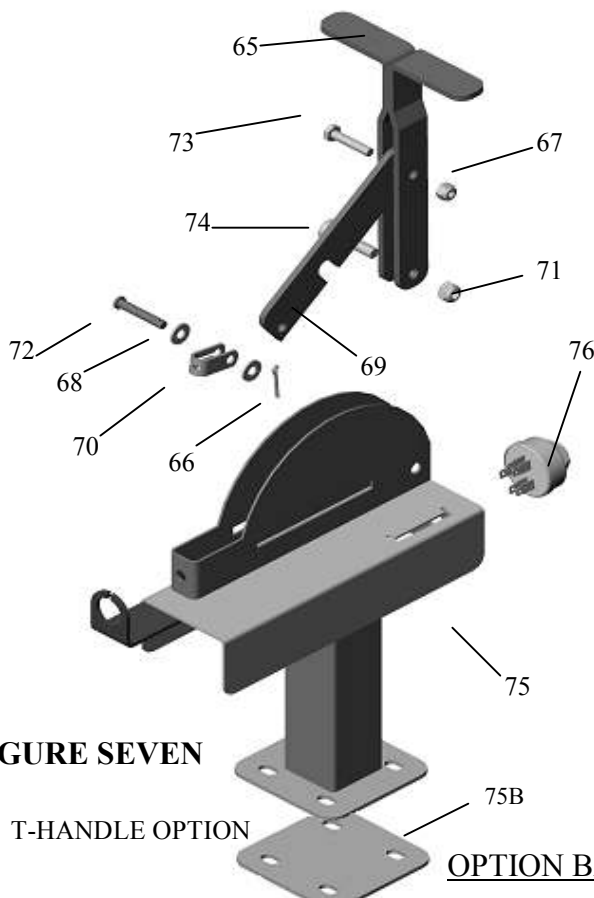

FIGURE SEVEN

T-HANDLE OPTION

OPTION BASED ON MODEL

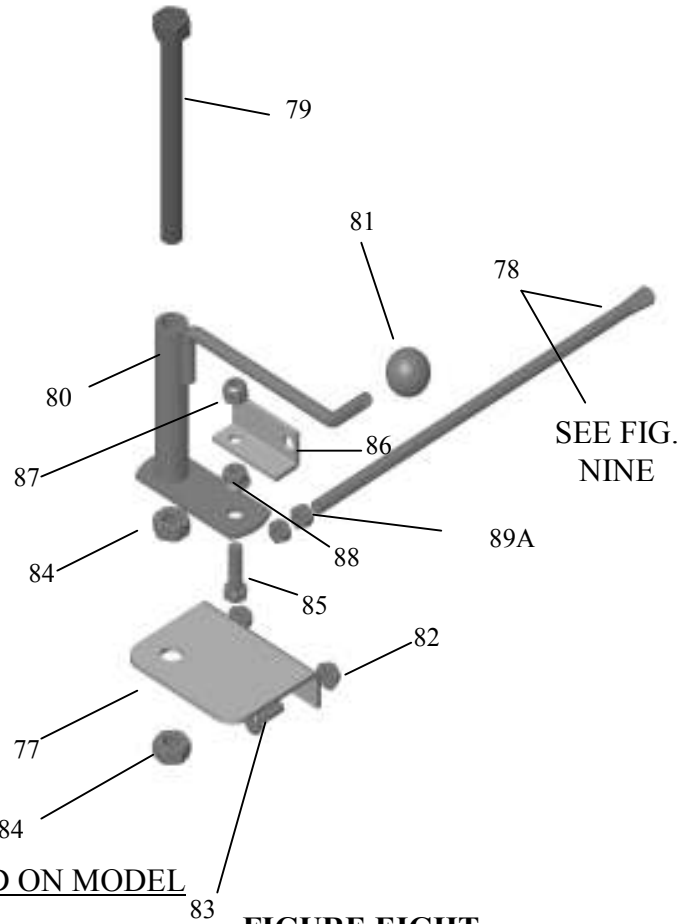

FIGURE EIGHT
STANDARD ENGAGE

ITEM #	DESCRIPTION	PART #
65	T-HANDLE LEVER	4463TK
66	COTTER PIN	NB597
67	1/4 NUT	NB180
68	WASHER	NB274
69	ENGAGE LINK	4461TK
70	CABLE CLEVIS	9023MOD
71	5/16 NUT	NB181
72	CLEVIS PIN	NB518
73	1/4 BOLT	NB560
74	5/16 TORX BOLT	NB591
75	CONSOLE WELDMENT	4602TK
76	KEY SWITCH (12 VOLT)	3623
	KEY SWITCH (Recoil Start)	KSM
	KEYS	KSK
	T-HANDLE ACCESSORY KIT (Recoil Start)	4498
	T-HANDLE ACCESSORY KIT (12V)	4607
	BLADE ENGAGE DECAL	OD10
	ON/OFF DECAL	OD99
	12 VOLT ON/OFF DECAL	OD28
75 B	CONSOLE MOUNT PLATE	4601TK
	5/16-18 BOLTS	NB138
	5/16-18 NUTS	NB181

ITEM #	DESCRIPTION	PART #
77	ENGAGE STANDOFF	4547TK
78	5/16 Spade Bolt	NB260
79	1/2 BOLT	NB155
80	ENGAGE LEVER	4548TK
81	HANDLE KNOB	B19BLACK
82	1/4 NUT	NB524
83	1/4 BOLT	NB250
84	1/2 NUT	NB121
85	5/16 BOLT	NB501
86	ENGAGE PIVOT	4578TK
87	5/16 NUT	NB181
88	5/16 NUT	NB170
	ON/OFF DECAL	OD10
89A	5/16-18 Nut	NB210Z

* = USE PAINT CODE:
TC=RED,G=GREEN,S=SLIVER,
TK=BLACK

EX: 4547C; 4578S

ITEM #	DESCRIPTION	PART #
89	3/8 NUT	NB280
90	WASHER	NB272
91	IDLER PULLEY	B527
92	WASHER	NB556
93	5/16 BOLT	NB254
94	IDLER SPRING	4422
95	5/16 NUT	NB170
96	BRAKE LINK	4532
97	3/8 BOLT	NB107
98	5/16 SPADE BOLT	NB260
99	EYE BOLT	V139EB
99A	5/16-18 NUT	NB210Z
100	3/8 NUT	NB182
101	IDLER BUSHING	6037
102	IDLER BRACKET	4530
103	1/4 NUT	NB524
104	1/4 BOLT	NB218
105	IDLER SPACER	6040
106	3/8 BOLT	NB618
106A	LOCK NUT	NB181

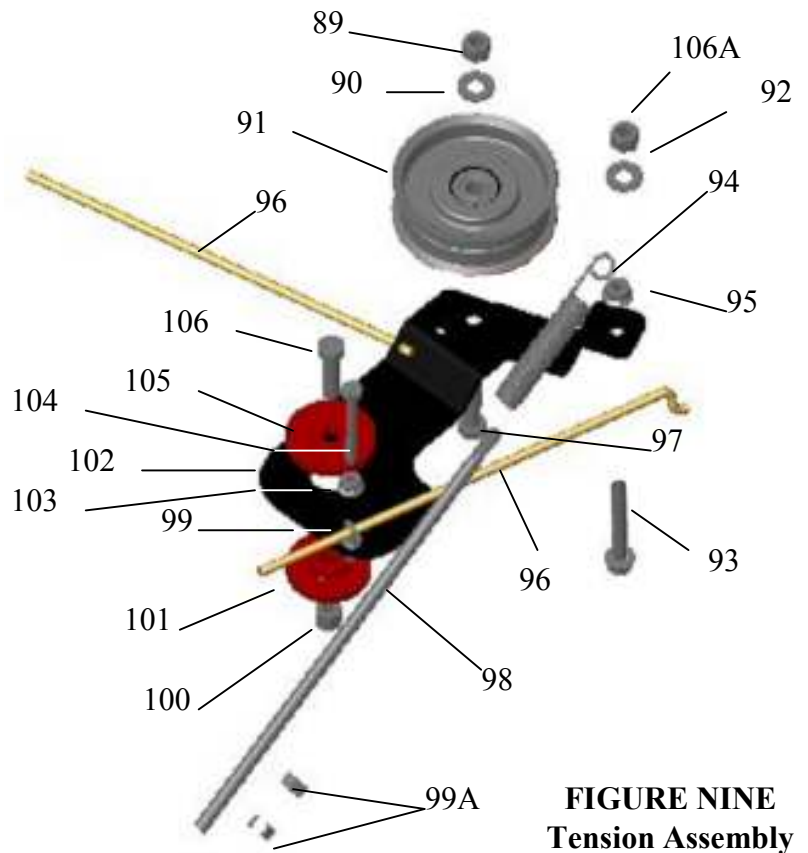

FIGURE NINE
Tension Assembly

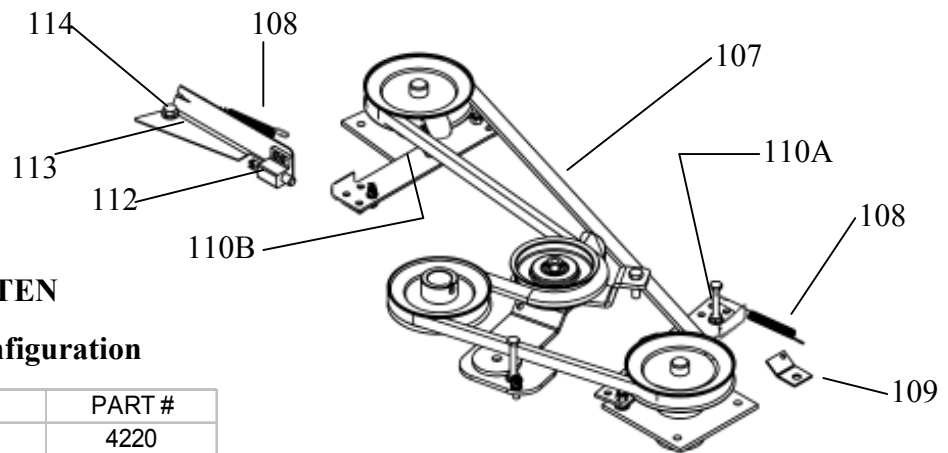
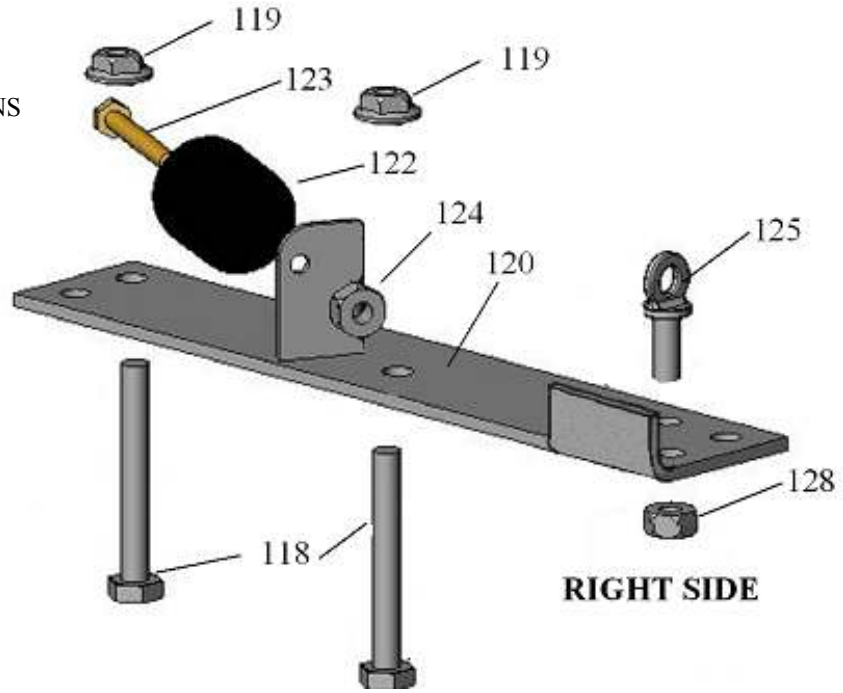

FIGURE TEN

Belt / Brake Configuration

ITEM #	DESCRIPTION	PART #
107	Belt 74"	4220
108	SPRING	T2SM
109	TENSION BRACKET	4593TK
110A	BRAKE ASSY (LEFT)	10591
110B	BRAKE ASSY (RIGHT)	10590
111	EYE BOLT	V139EB
112	NEUTRAL SWITCH	3695
	8-32 BOLT/NUT	NB 197/NB 201
113	SWITCH BRACKET	4301TK
114	5/16 BOLT/NUT	NB596/NB170

FIGURE ELEVEN
BRAKE ARM CONFIGURATIONS



RIGHT SIDE

NOTE: Parts shown on this page replace the parts which originally came on the mower.

Item #	Description	Part #
118	1/4-20 BOLT	NB162
119	1/4-20 NUT	NB524
120	BRAKE ARM	10589
121	1/4-20 NYLOCK	NB180
122	BRAKE PAD	9039
123	10-24 BOLT	NB710
124	10-24 KEP NUT	NB172
125	EYE BOLT	V139EB
128	1/4-20 NUT	NB180
129	1/4-20 BOLT	NB102
148	1/4-20 x 2 BOLT	NB218

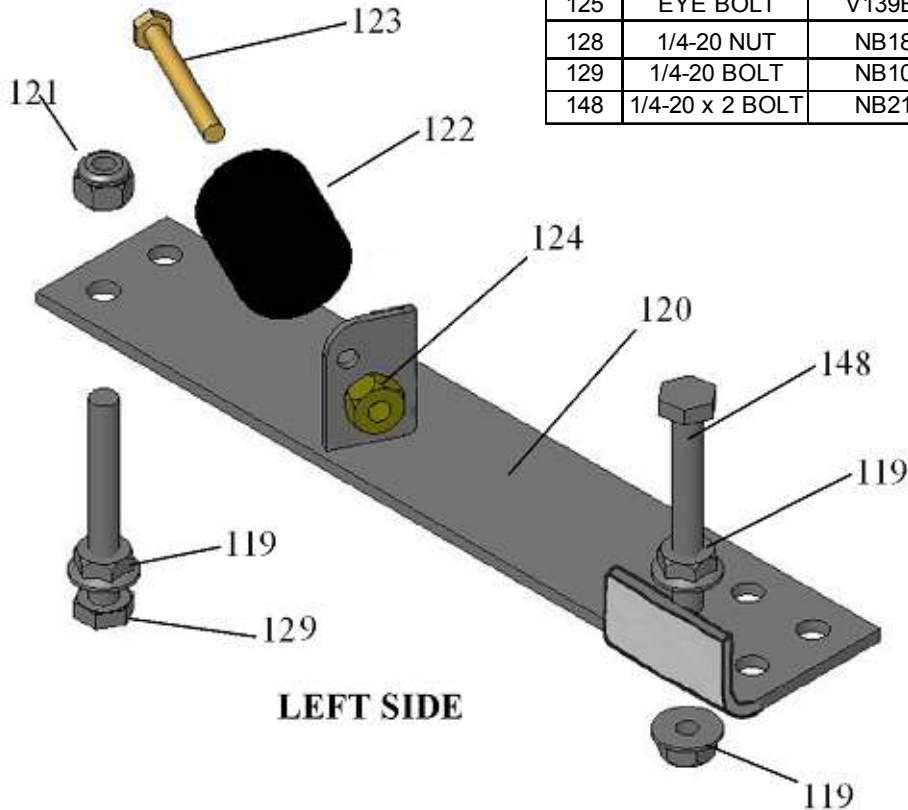

LEFT SIDE

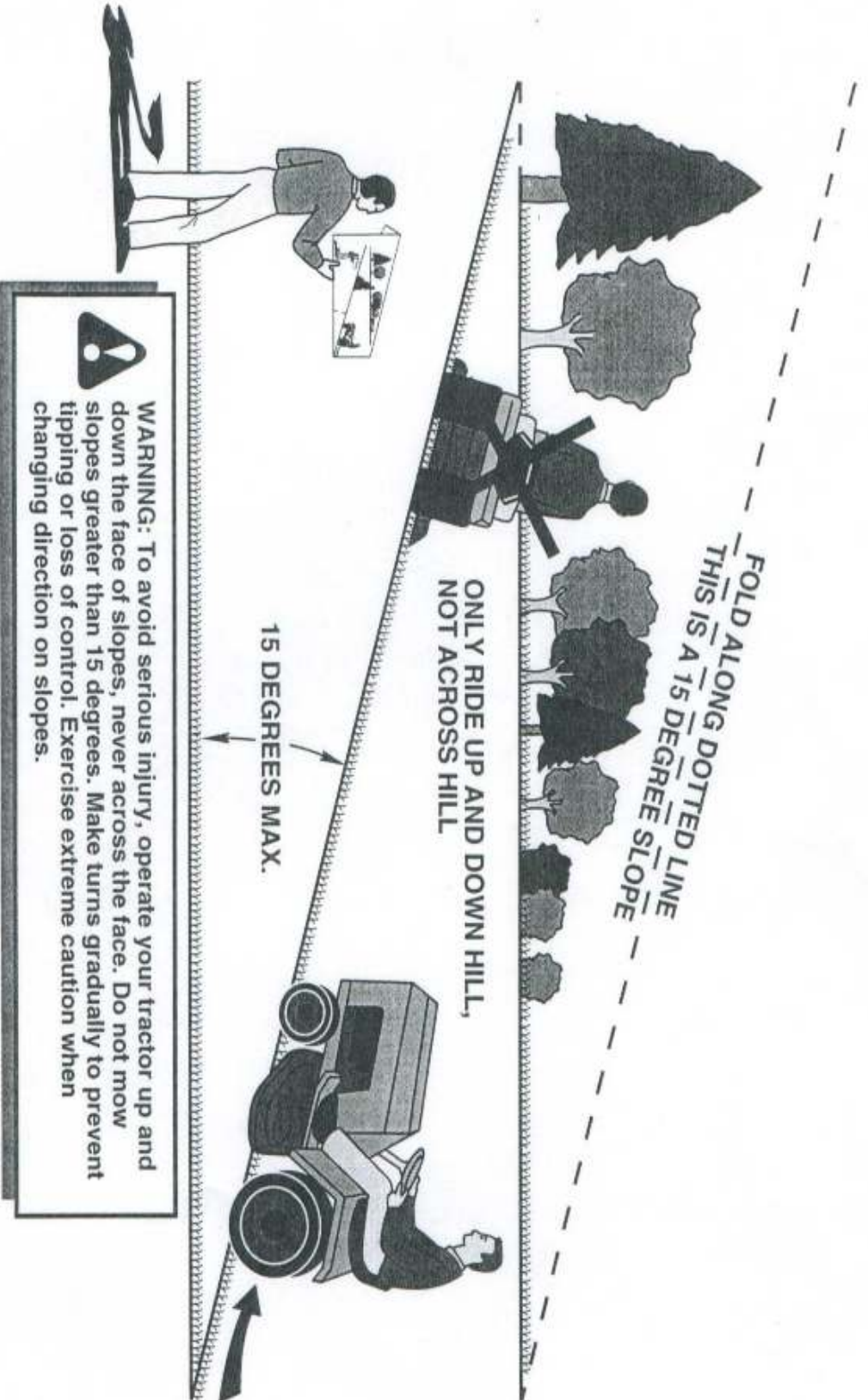



OWNER'S MANUAL

**MODEL NO.
POL10544C**

POLARIS 44" FINISH CUT TRAILMOWER

HOW TO ORDER REPAIR PARTS:

Each TrailMower has its own serial number. Each engine has its own serial number. The serial number for the TrailMower will be found on the right hand side of the drive belt housing. The serial number for the engine will be found on the top of the blower fan housing.

All TrailMower parts listed herein may be ordered directly from Swisher Mower & Machine Co. Inc., your nearest Swisher dealer, or from our website. www.swisherinc.com All engine parts may be ordered from the nearest dealer of the engine supplied with your mower.

WHEN ORDERING PARTS, PLEASE HAVE THE FOLLOWING INFORMATION AVAILABLE:

- * PRODUCT - T-44 FINISH CUT TRAILMOWER
- * SERIAL NUMBER - _____
- * MODEL NUMBER - _____
- * ENGINE MODEL NUMBER - _____
TYPE - _____
- * PART NUMBER
- * PART DESCRIPTION

www.swisherinc.com
TELEPHONE - 1-800-222-8183
FAX - 1-660-747-8650

SWISHER MOWER & MACHINE CO. INC.
1602 CORPORATE DRIVE
WARRENSBURG, MO 64093

SWISHER MOWER & MACHINE CO. INC.