

SWISH-ERR

T-60 TRAILMOWER OPERATOR'S MANUAL

*IMPORTANT INFORMATION
READ CAREFULLY
DO NOT THROW AWAY*

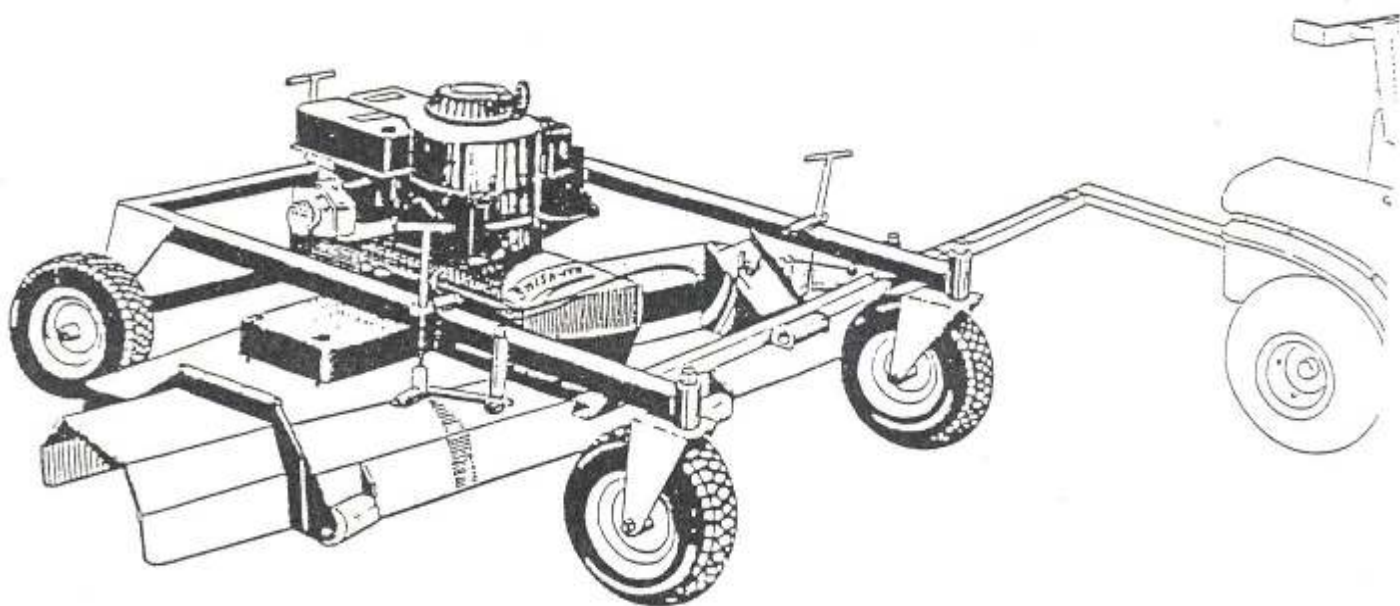

*SWISHER MOWER AND MACHINE CO., INC.
P.O. BOX 67, WARRENSBURG, MISSOURI 64093
PHONE: 816-747-8183*

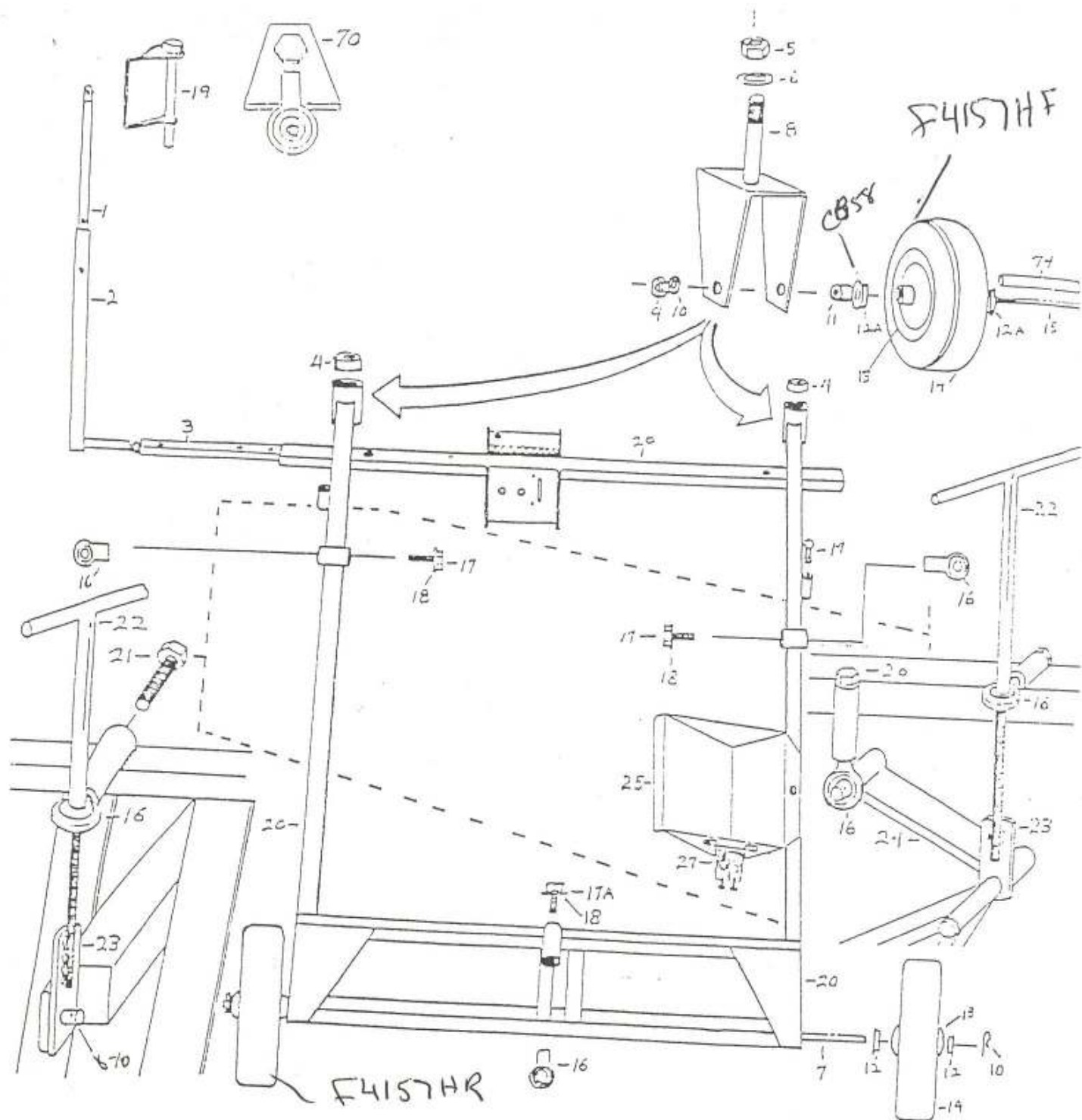

KEY

1	061	TONGUE
2	061A	TONGUE HINGE
3	062	TONGUE EXTENSION
4	066	BLANKING
5	063B	BOLT FOR CASTER FORK
6	063W	WASHER FOR CASTER FORK
7	064	WELK AXLE
8	065	CASTER FORK
9	TX	1/2" NUT
10	TXNC	1/2" COTTER PIN
11	063	SPACER
12	H157B	BLANKING
13	A157H	WHEEL
14	F4157H	WHEEL TIRE TUBE
15	070	AXLE BOLT

KEY

16	067	SWIVEL ROD END
17	068	BOLT
17A	072	BOLT
18	069	BELLEVILLE WASHER
19	H11	HITCH SAFETY PIN
20	071	MAIN FRAME
21	073	BOLT
22	H7	ADI HANDLE
23	074	THREADED LINK
24	075	STABILIZER
25	076	BATTERY CASE
26	077	BOLT
27	S0L	SWENOID
28	H10	HITCH ADAPTER
29	091	SPACER

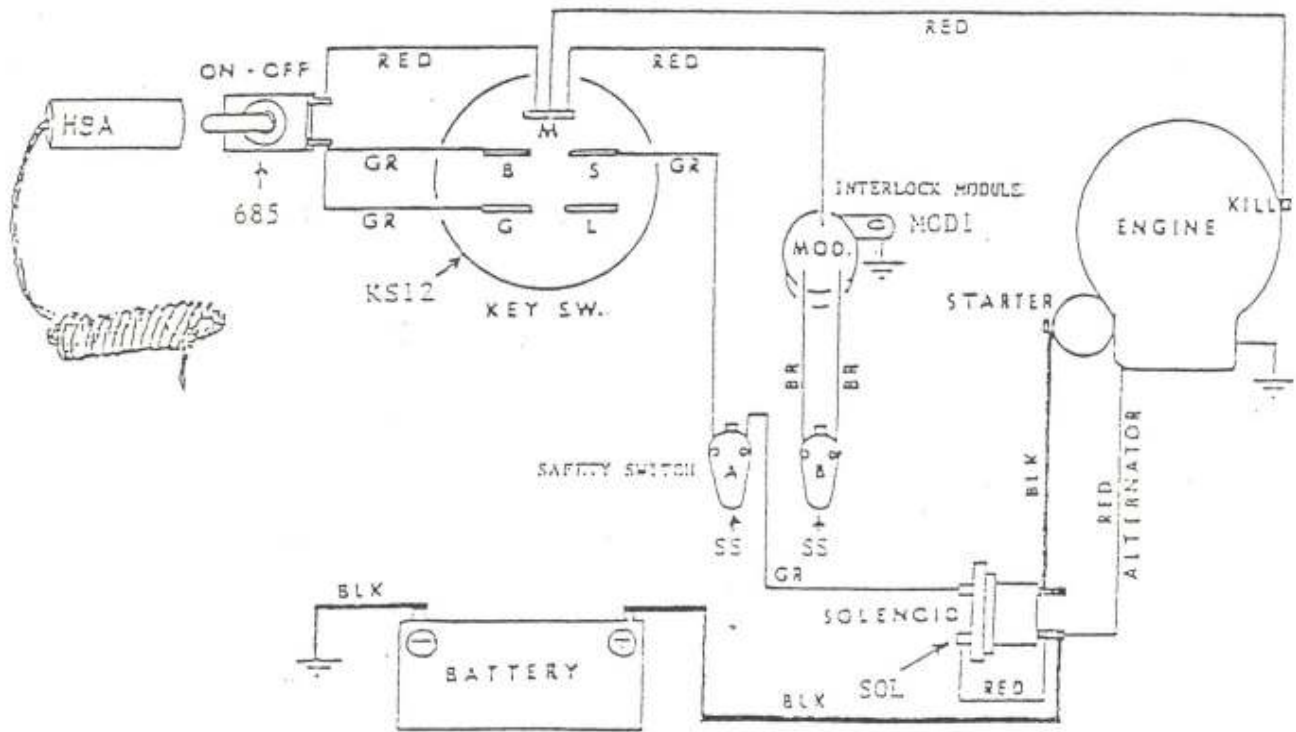
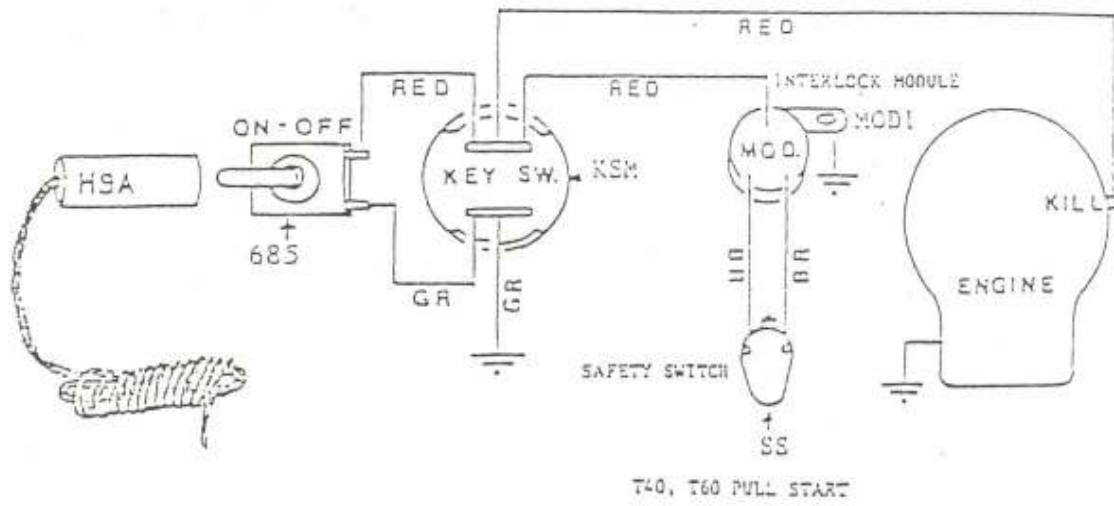

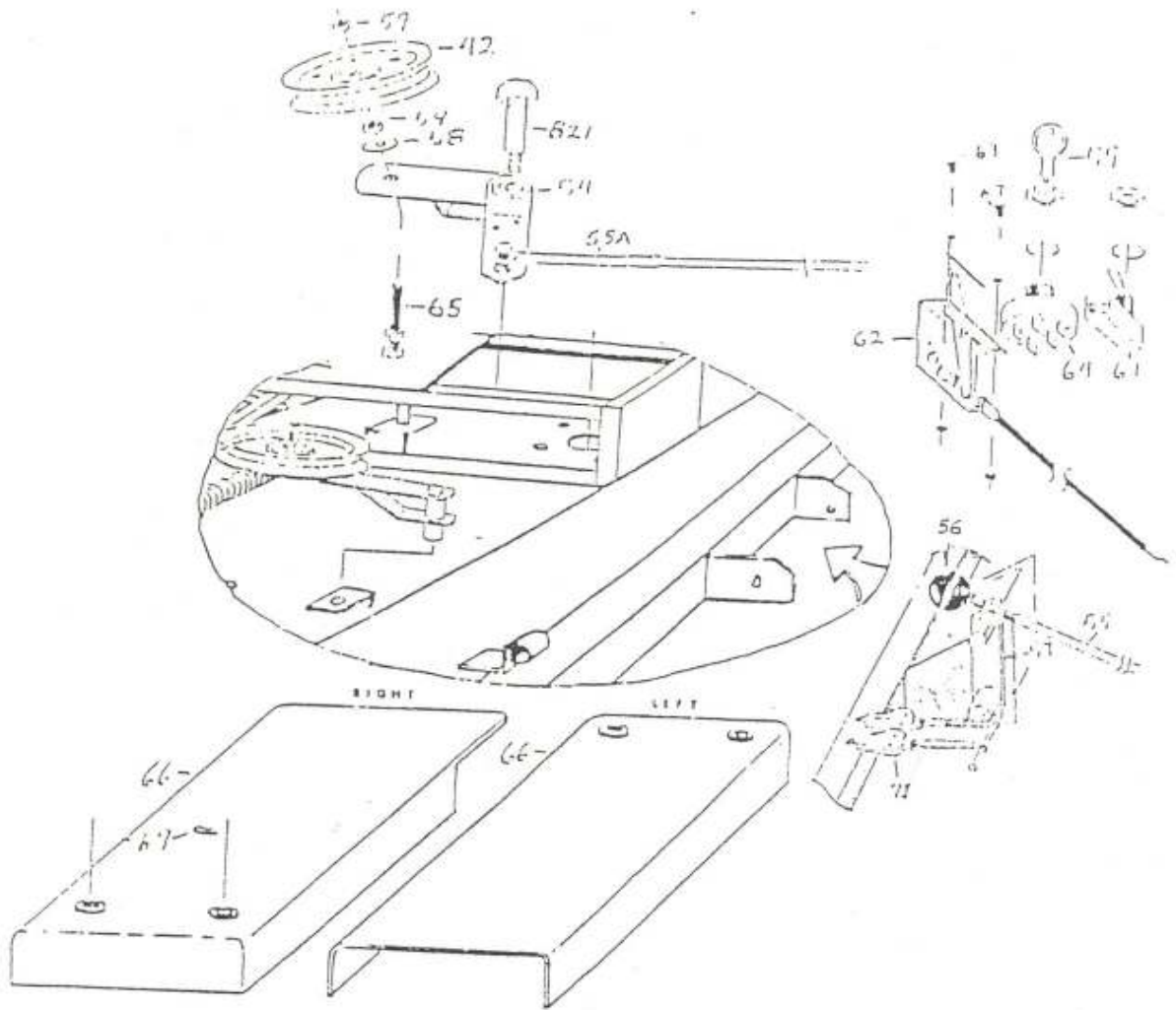

KEY

55	682	CLUTCH ROD
55A	682S	CLUTCH ROD SPRING
56	B19	KNOB
57	683	CONTROL ARM AND SWIVEL
58	1427W	WASHER
59	B26	NUT
61	685	KILL SWITCH

KEY

62	686	THROTTLE AND CABLE ASSEMBLY
63	687	SCREWS AND NUTS FOR 686 EA
64	KS12	KEY SWITCH
65	B28	BOLT
66	6155L	BELT GUARD, LEFT
66	6155R	BELT GUARD, RIGHT
67	A155H	HAIR PIN LOCK
71	SS	SAFETY SWITCH

54 681 TK

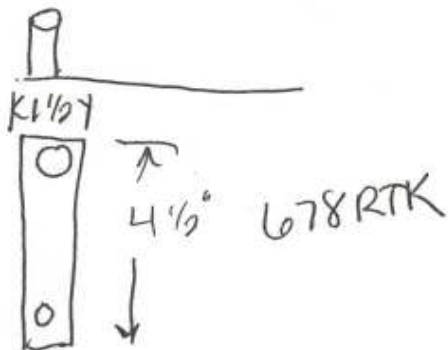

1/2" x 1/2"

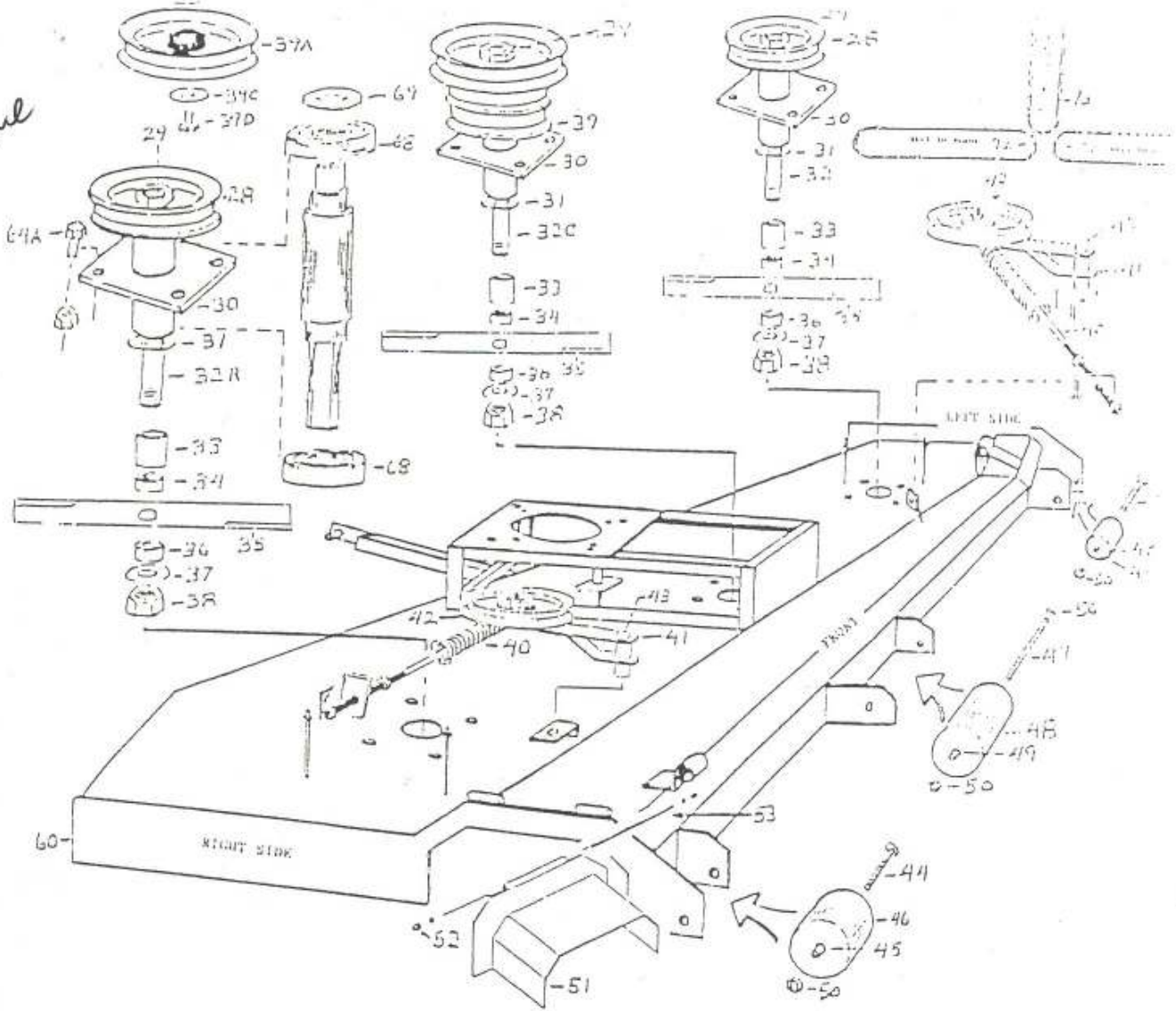

KEY

28	6104	PULLEY	
29	A108	BLADE NUT	
30	B94	BLADE SHAFT HOUSING	
31	B98W	DIRT SHIELD	
32	<i>5100</i>	LEFT BLADE SHAFT	<i>- 6.875</i>
32C	<i>B100C</i>	CENTER BLADE SHAFT	<i>- 8 3/4</i>
32R	<i>B100R</i>	RIGHT BLADE SHAFT	<i>- 7.50</i>
33	B103	1" SPACER	
34	B102	1/2" SPACER	
35	660	BLADE SET OF THREE	
36	B101	1/4" SPACER	
37	B108L	BLADE NUT LOCK	
38	B108	BLADE NUT	
39	687	3 STEP PULLEY	
39A	688	ENGINE PULLEY	
39B	689	PULLEY SPACER	
39C	699	BELLEVILLE WASHER	
39D	6100	CRANKSHAFT BOLT	
40	B25R	ROD AND SPRING	
41	678	IDLER ARM	
42a	B427	IDLER PULLEY (Ser #Y5740 and earlier)	
42b	B527	IDLER PULLEY (Ser #Y5741 and later)	

KEY

43	B21	SHOULDER BOLT
44	BK4	BOLT
45	BR4B	SPACER BUSHING
46	SWR3	ROLLER LEFT OR RIGHT
47	BR7	BOLT
48	R7	CENTER ROLLER
49	RS7	SPACER BUSHING
50	BR47N	NUT
51	679	CHUTE
52	FR54N	NUT
53	660	BOLT FOR CHUTE
54	661	CLUTCH IDLER ARM
55	662	CLUTCH ROD
55A	662S	CLUTCH ROD SPRING
58	B427W	WASHER
60	664	CUTTER DECK 60"
60A	6101	BOLT FOR BLADE SPINDLE
66	598	BLADE BEARING
69	B104W	WASHER
72	60LR	BELT TO BLADES LEFT OR RIGHT
73	69U	BELT TO ENGINE

*Steel tank 6102 tank
6102N bracket old to new*

T-60 TRAILMOWER PARTS LIST

660	Blade Set (3 - 20 1/2" Blades)	A157	Wheel
660S	Blade (1 - 20 1/2" Blade)	B21	Shoulder Bolt
661	Tongue	B25R	Rod & Spring
661A	Tongue Hinge	B98	Bearing
662	Tongue Extension	B98W	Dirt Shield
663	Spacer	B99	Blade Shaft Housing
664	Rear Axle	B100	Left Blade Shaft - B99C
665	Caster Fork	B100C	Center, Blade Shaft - B99CC
66LR	Blade Belt (Left or Right)	B100R	Right, Blade Shaft - B99CR
667	Swivel Rod End	B101	1/4" Spacer
668	Bolt	B102	1/2" Spacer
669	Belleville Washer	B103	1" Spacer
670	Axle Bolt	B104	Pulley
671	Main Frame	B104W	Washer
672	Bolt	B108	Blade Nut
674	Threaded Link	B108L	Blade Nut Lock
675	Stabilizer	B427	Idler Pulley ser #Y5740 and older
676	Battery Case	B427W	Washer
677	Bolt	B527	Idler Pulley ser #Y5741 and newer
678	Idler Arm	BR4	Bolt
679	Chute	BR4B	Spacer Bushing
680	Bolt for Chute	BR7	Bolt
681	Clutch Idler Arm	BR47N	Nut
682	Clutch Rod	CB58	Bearing
682S	Clutch Rod Spring	F157B	Bearing
684	Cutter Deck 60"	F4157	Wheel, Tire & Tube
687	3 Step Pulley	FR54N	Nut
688	Engine Pulley	H7	Adjuster Handle
689	Pulley Spacer	H10	Hitch Swivel Adapter
690	Engine Belt	H11	Hair Pin Latch
691	Spacer	R7	Center Roller
699	Belleville Washer	RS7	Spacer Bushing
6100	Crankshaft Bolt	SOL	Solenoid
6101	Bolt for Blade Spindle	SWR3	Roller Left or Right
A104	Washer	T2K	1/2" Nut
A108	3/4" Nut	T218C	Cotter Key

6.875 -

8.75 -

7.5 -