

Visit us at: [www.swisherinc.com](http://www.swisherinc.com)

**SWISHER**

# OWNER'S MANUAL

**MODEL NO.  
WB80042F**



Read and follow all Safety  
Rules and Instructions  
before operating this  
equipment.

Rev. 12.18.2002

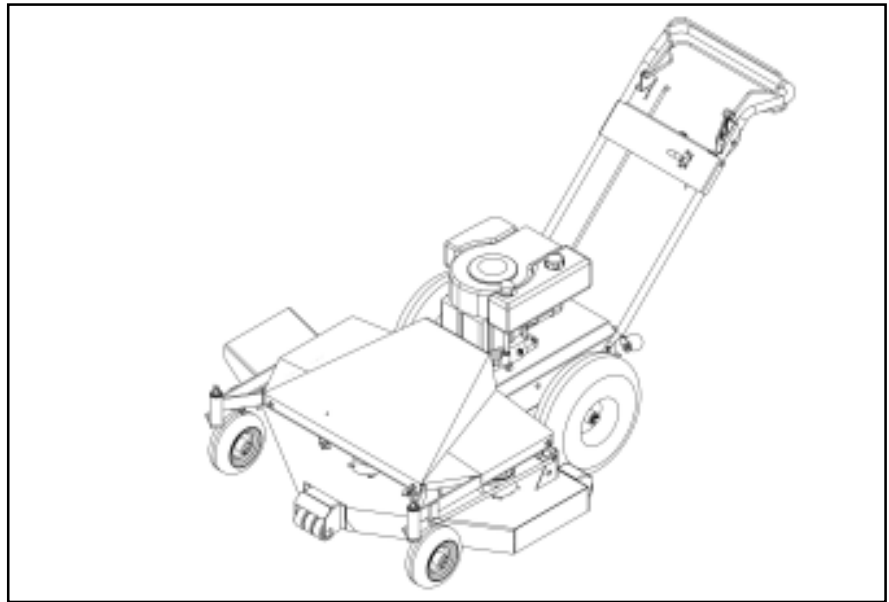

## **THE FINISHING TOUCH** **42" FINISH CUT MOWER SELF PROPELLED WALK BEHIND**

**Assembly  
Operation  
Service and Adjustment  
Repair Parts**

**SWISHER**

1602 CORPORATE DRIVE, P.O. BOX 67, WARRENSBURG, MISSOURI 64093  
PHONE (660) 747-8183 FAX (660) 747-8650

**Manufacturing quality lawn care equipment since 1945**

*Made In The*

**USA**

## SAFETY AND OPERATIONAL DECALS

Replace decal immediately if damaged. Order by part number from Swisher Mower and Machine Co. Inc.



OD30 – WARNING DECAL



OD36 – DEFLECTOR DECAL



OD43 – FLYING DEBRIS DECAL



OD55 – DANGER DECAL



OD29 – SPINNING BLADE DECAL

## SERVICE AND ADJUSTMENTS

Stop engine, let all moving parts come to a complete stop. Disconnect spark plug.

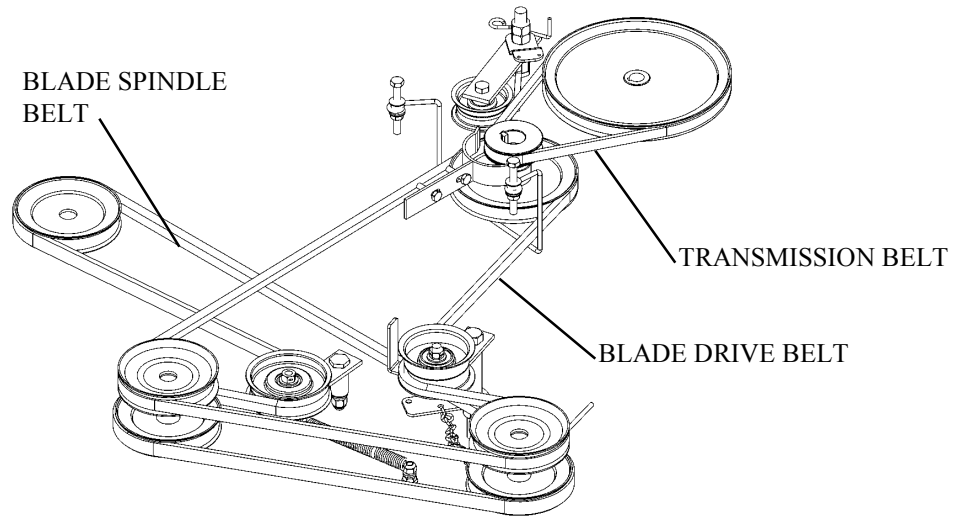

### BELTS CONFIGURATION

#### BLADE SPINDLE BELT REPLACEMENT

##### REMOVAL

- *Stop engine, let all moving parts come to a complete stop. Disconnect spark plug.*
- Remove belt cover.
- Remove Blade Drive Belt. (See Blade Drive Belt replacement.)
- Pull tension idler away from Blade Spindle Belt to relieve tension.
- Remove belt.

##### INSTALLATION

- Pull tension idler away from belt.
- Install belt according to above configuration.
- Install Blade Drive Belt as shown.
- Install belt cover and tighten hardware.

#### BLADE DRIVE BELT REPLACEMENT

##### REMOVAL

- *Stop engine, let all moving parts come to a complete stop. Disconnect spark plug.*
- Disengage all blade controls by releasing the bails.
- Remove belt cover.
- Rotate belt off pulleys and pull belt through motor belt guide.

##### INSTALLATION

- Route belt as shown.
- Adjust engage idler tension. Belt should be snug during engagement of blade latch. Too much tension will not allow the blade latch to function properly.
- Tighten nuts on blade engage cable when finished.
- Install belt cover and tighten hardware.

## WHEEL DRIVE BELT REPLACEMENT

### REMOVAL

- *Stop engine, let all moving parts come to a complete stop. Disconnect spark plug.*
- Remove belt cover.
- Remove Blade Drive Belt, (See “Blade Drive Belt replacement”)
- Locate belt guide for wheel drive belt and loosen.
- Remove wheel drive belt.

### INSTALLATION

- Install belt as shown.
- Adjust belt guide snug against motor pulley and back off ¼”.
- Tighten belt guide hardware.
- Install Blade Drive Belt (see “Blade Drive Belt installation”).
- Install belt cover and tighten hardware.

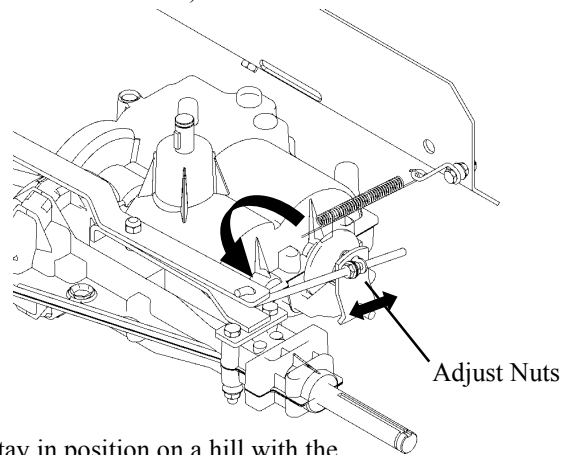
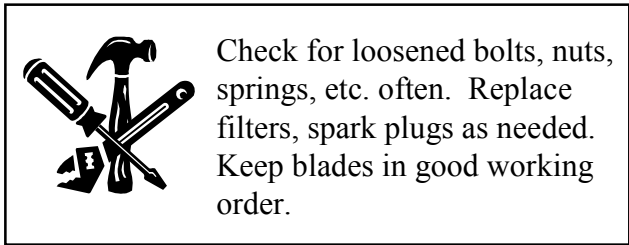

## WHEEL BRAKE ADJUSTMENT

Adjustment may be necessary if the unit does not stay in position on a hill with the operator bails released, or if the brake drags while in neutral with the “GROUND CONTROL” bail engaged.

### PROCEDURE

- *Stop engine, let all moving parts come to a complete stop. Disconnect spark plug.*
- Release “GROUND CONTROL” bail.
- Adjust nuts forward or backward. When the “GROUND CONTROL” bail is disengaged there should be constant tension on the brake arm.
- All tension should be off brake arm when “GROUND CONTROL” bail is engaged.
- Tighten adjustment nut when finished and re-attach spring, if necessary.

## WHEEL DRIVE BELT ADJUSTMENT

Adjustment may be necessary if loss of traction occurs due to belt slippage.

### PROCEDURE

- Adjust “GROUND CONTROL” cable in or out to achieve maximum traction.
- Too much tension will not allow the “GROUND CONTROL” bail to fully activate.
- Too little tension will allow the belt to slip, resulting in loss of traction.
- “GROUND CONTROL” bail should fully close against handlebars when functioning properly.

## OVERALL ASSEMBLY

When ordering painted parts, please indicate with corresponding letters: C = Red Parts

TK = Textured Black Parts

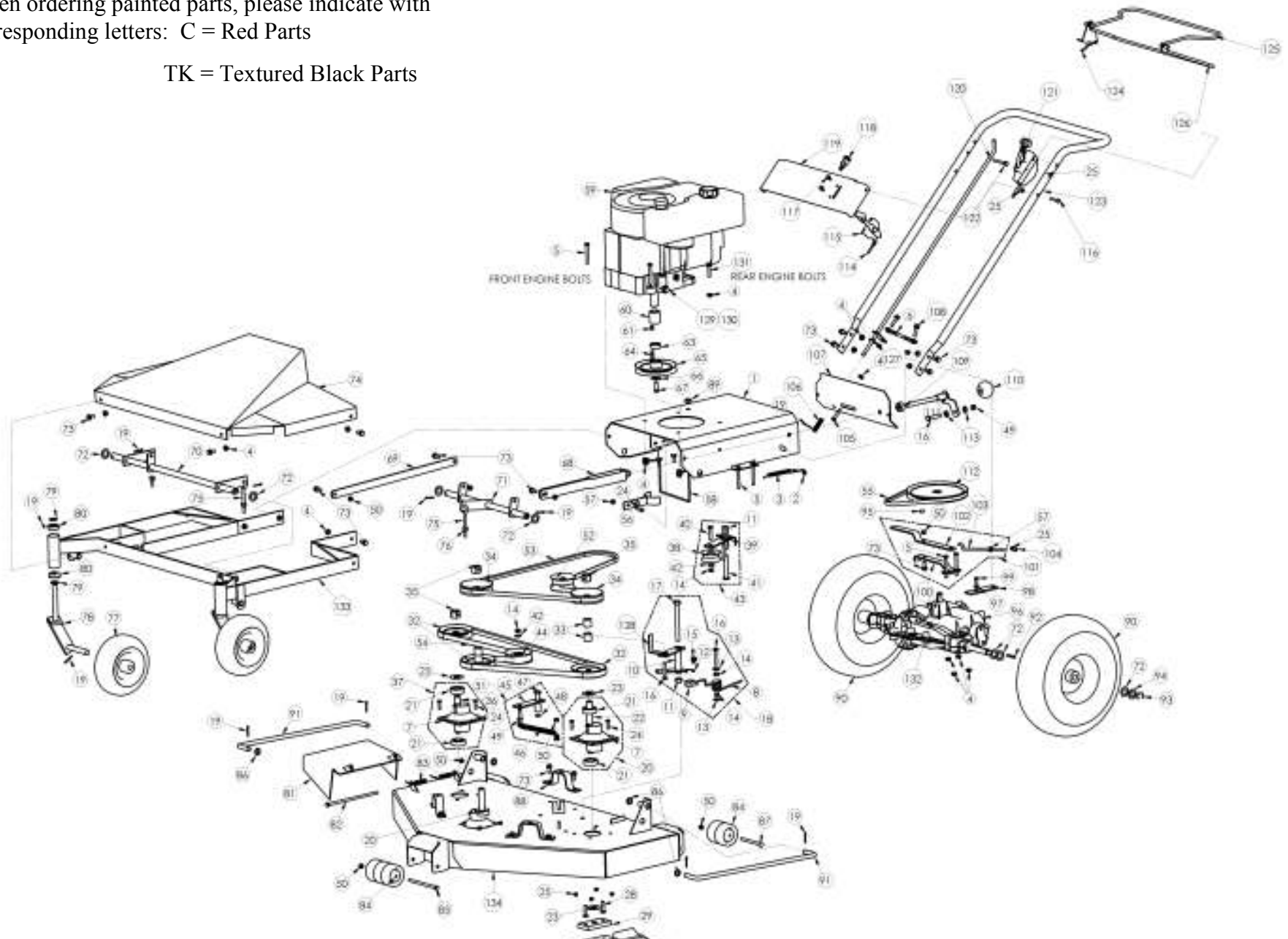

## REPLACEMENT PARTS

When ordering painted parts, please indicate with corresponding letters: C = Red Parts;  
TK = Textured Black Parts (ex. 4207TK, 4237C)

Item #	Description	Part #	Item #	Description	Part #
1	Motor Base	4270	46	Tension Spring	682S
2	Wire Link	BRS6H	47	1/2 x 1 9/16 Shoulder Bolt	NB220
3	Link Spring	T2SM	48	5/16 SAE Washer	NB275
4	5/16-18 Serrated Flange Nut	NB170	49	3/8-16 Grade 2 Nut	NB212
5	5/16-18 x 2 1/2 Grade 5 Bolt	NB138	50	5/16-18 Nylock Nut	NB181
6	Shift Linkage	4282	51	Tension Idler Kit	4263
7	Blade Driver Housing	B99	52	Blade Engage Pulley	7509
8	Brake Spring	BT297	53	Blade Drive Belt	4220
9	Brake Pad	BP370	54	Blade Spindle Belt	4219
10	Blade Engage Idler	4262	55	Wheel Drive Belt	2414
11	1/2 -13 Nut	NB213Z	56	Transmission Belt Guide	2451
12	Brake Pad Clip	BP370S	57	1/4-20 Flange Nut	NB524
13	5/16 Flat Washer	NB556	58	Blade Drive Belt Guide	4234
14	3/8 -16 2-way Locknut	NB280	59	8HP B&S Engine	N/A
15	5" Chain Links	AS080	60	Upper Engine Spacer	689L
16	3/8-16 x 2 Grade 2 bolt	NB231	61	1/4 x 1/2 Key Stock	4258
17	1/2-13 x 5 Grade 5 bolt	NB155	62	Upper Engine Pulley	2411
18	Blade Engage Idler Kit	4280	63	Lower Engine Spacers	BB105SL
19	1/8 x 1 Cotter Pin	NB126	64	1/4 x 1 Key Stock	9031
20	Center & Left Blade Driver Kit	9080	65	Lower Engine Pulley	688
21	Blade Bearing	B98	66	Belleville Washer	699
22	Center & Left Blade Shaft	9075	67	7/16-20 x 1 1/2 Grade 5 Bolt	NB637
23	Washer	B98W	68	Height Adjust Arm	4275
24	1/4-20 x 1 Grade 5 Bolt	NB250	69	Front / Rear Torsion Connector	4235
25	1/4-20 Nylock Nut	NB180	70	Front Torsion Bar	4233
26	15" Blade	4221	71	Rear Torsion Bar	4236
27	Serrated Belleville Washer	NB607	72	3/4 x 18 GA Washer	NB179
28	3/8 - 24 x 1 1/4 Grade 5 Bolt	NB166	73	5/16-18 x 3/4 Serrated Flange Bolt	NB596
29	Blade Mounting Plate	9008	74	Plastic Belt Cover	4257
30	3/8-24 2 Way Lock Nut	NB216	75	3/8-16 x 3 Eye Bolt	NB635
31	3/8-24 x 1 Grade 5 Bolt	NB238N	76	3/8-16 Nylock Nut	NB182
32	Lower Blade Pulley	B4104	77	Front Tire & Wheel	4218
33	Pulley Spacer	6104RS	78	Caster	4266
34	Upper Blade Pulley (Center & Left Only)	B104	79	5/8 x 10 GA Washer	NB149
35	3/4-16 2 Way Lock Nut	NB629	80	5/8 Flanged Bearing	F157B
36	Right Blade Shaft	9077	81	Grass Chute	4261
37	Right Blade Driver Kit	9079	82	5/16-18 x 8 1/2 Grade 2 Bolt	NB136
38	Transmission Idler Pulley	B27	83	Grass Chute Spring	CH5S
39	Transmission Idler	4276	84	Plastic Roller	AS001
40	3/8-16 x 1 1/2 Grade 5 Bolt	NB107	85	5/16-18 x 5 1/2 Grade 5 Bolt	NB521
41	1/2-13 x 2 1/2 Grade 5 Bolt	NB588	86	1/2 x 14 GA Washer	NB177
42	3/8 SAE Washer	NB272	87	5/16-18 x 4 Carriage Bolt	NB101
43	Transmission Idler Kit	4281	88	Hanger Bracket	4216
44	Tension Idler Pulley	B527	89	1/2-13 2 Way Jam Lock Nut	NB121
45	Tension Idler	6681	90	Rear Tire & Wheel	4217

## REPLACEMENT PARTS

When ordering painted parts, please indicate with corresponding letters: C = Red Parts;  
TK = Textured Black Parts (ex. 4207TK, 4237C)

Item #	Description	Part #
91	Sway Bar	4207
92	3/16 x 1 1/2 Keystock	2434
93	3/4 E-Clip	NB621
94	3/4 x 10 GA Washer	NB184
95	5/16-18 x 1/2 Set Screw	NB192
96	4 Speed Transmission	4256
97	1/4 SAE Washer	NB274
98	Shift Link	4223
99	1/4-28 x 3/4 Grade 5 Bolt	NB620
100	Brake Mount	4273
101	Brake Mount Kit	4271
102	Transaxle Brake Pivot	4247
103	Transaxle Brake Link	4264
104	1/4-20 x 3/4 Eye Bolt	V139EB
105	5/16-18 x 1 Grade 5 Bolt	NB501
106	Gear Shift Spring	TR148S
107	Rear Cover	4299
108	5/16-18 x 1 1/4 Serr. Flange Bolt	NB253
109	Thrust Bearing	T151
110	Plastic Knob	4857
111	Crank Handle	4274
112	Transmission Pulley	2410
113	3/8 Hardened Washer	NB196
114	Wiring Harness	4268
115	Throttle Control	4226
116	1/4-20 x 1 1/2 Grade 2 Bolt	NB104
117	1/4-20 x 1/2 Self-tapping Bolt	NB114
118	ON/OFF Key Switch	KSM
119	Throttle Console	4292
120	Gear Shifter	4260
121	Blade Engage Latch	4295
122	1/4-20 x 2 1/2 Grade 5 Serr. Flange Bolt	NB208
123	Operator Handle	2402
124	Transmission Cable	2432
125	Operator Presence Bail (Upper)	4294
126	Ground Control Bail (Lower)	4291
127	3/16 x 1 Roll Pin	NB123
128	Belt Guide	4283
129	Oil Drain Cap	AS123
130	Oil Drain Valve	AS122
131	5/16-18 x 1 1/2 Serr. Flange Bolt	NB254
132	3/16 x 3/4 # 9 Woodruff Keystock	NB638
133	Frame	4269
134	Deck	4250



**OWNER'S  
MANUAL  
MODEL NO.  
WB80042F**

**THE FINISHING TOUCH  
42" FINISH CUT MOWER SELF PROPELLED  
WALK BEHIND**

Each cutter has its own model number. Each engine has its own model number. The model number for the cutter will be found on the right hand side of the motor base. The model number for the engine will be found on the top of the blower fan housing.

All cutter parts listed herein may be ordered directly from Swisher Mower & Machine Co. Inc. or your nearest Swisher dealer.

All engine parts may be ordered from the nearest dealer of the engine supplied with your cutter.

WHEN ORDERING PARTS, PLEASE HAVE THE FOLLOWING INFORMATION AVAILABLE:

- \* PRODUCT – FINISHING TOUCH
- \* SERIAL NUMBER - \_\_\_\_\_
- \* MODEL NUMBER - \_\_\_\_\_
- \* ENGINE MODEL NUMBER - \_\_\_\_\_
- TYPE - \_\_\_\_\_
- \* PART NUMBER
- \* PART DESCRIPTION

TELEPHONE - 1-800-222-8183

FAX - 1-660-747-8650

**SWISHER MOWER & MACHINE CO. INC.**  
1602 CORPORATE DRIVE P.O. BOX 67  
WARRENSBURG, MO 64093

Visit us at: [www.swisherinc.com](http://www.swisherinc.com)



**SWISHER MOWER & MACHINE CO. INC.**