

**ARTIC CAT
WINCH MOUNT
KIT # 11653**

INSTRUCTIONS

1. Remove (4) M8 bolts and wire mesh grill from the front bumper. Retain for later use when winch mount is removed.
2. Install fairlead roller assembly to winch mount plate using (2) 5/16 flange bolts and (2) 5/16 flange nuts. Arrange fairlead roller so the larger roller will be on the bottom when the plate is assembled to the atv.
3. Assemble the winch of your choice to the winch mount plate with the hardware supplied with the winch. Note the winch is mounted upside down.
4. Position and assemble the winch mount plate to the front bumper using (4) M8 X 20 bolts and (4) 5/16 flat washers. These are assembled to the bolt hole locations left empty by step 1.
5. Using the instructions supplied with the winch wire accordingly.

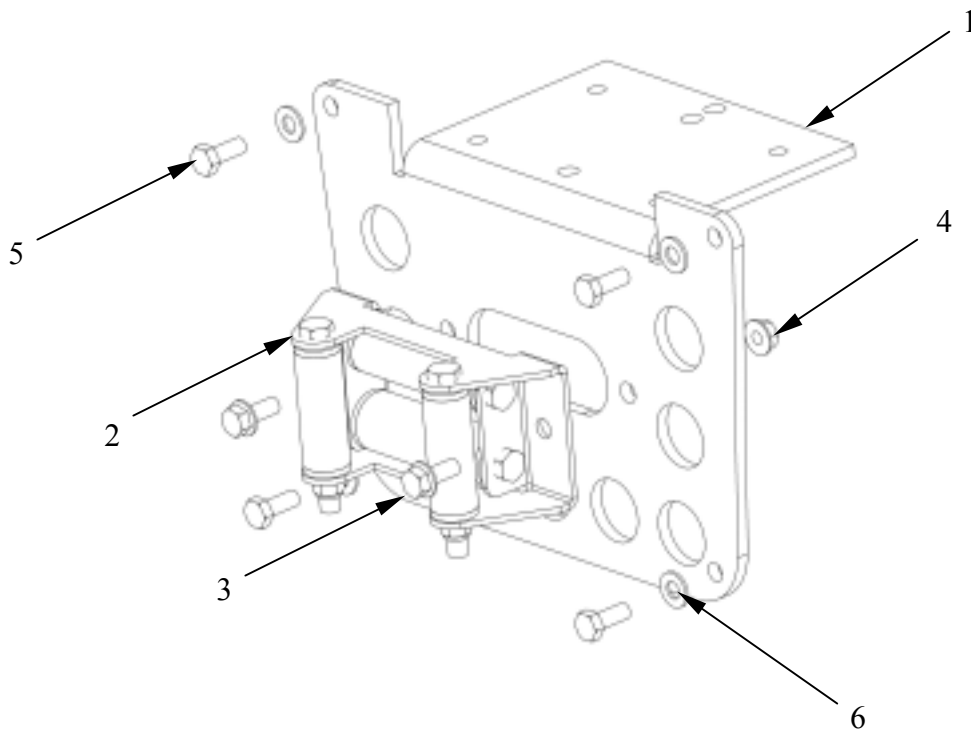

ITEM	QTY.	PART NO.	DESCRIPTION
1	1	8042TK	Winch Mount Plate
2	1	NA	Fairlead Assembly (Purchase Separately)
3	2	NB-596	5/16-18 x 3/4 Serrated Flange Bolt
4	2	NB-170	5/16-18 Serrated Flange Nut
5	4	NB-719	M8 - 1.25 X 20 Hex Bolt
6	4	NB275	5/16 SAE Washer

Please Call 1 800 222-8183 with questions or comments.