

SWISHER

swisherinc.com

**OWNER'S
MANUAL**

**MODEL NO.
ZT17542**



IMPORTANT
Read and follow all
Safety Precautions
and Instructions
before operating this
equipment.

Rev.02.01.2002



**“Z” SERIES
ZERO TURN HYDROSTATIC DRIVE**

**Assembly
Operation
Service and Adjustment
Repair Parts**

SWISHER

1602 CORPORATE DRIVE, WARRENSBURG MISSOURI 64093
PHONE 660-747-8183 FAX 660-747-8650

Manufacturing quality lawn care equipment since 1945

Made In The
USA

LIMITED WARRANTY

The manufacturer's warranty to the original consumer purchaser is: This product is free from defects in materials and workmanship for a period of two (2) years from the date of purchase by the original consumer purchaser. We will repair or replace, at our discretion, parts found to be defective due to materials or workmanship. This warranty is subject to the following limitations and exclusions:

- 1) Engine Warranty All engines utilized on our products have a separate warranty extended to them by the individual engine manufacturer. Any engine service difficulty is the responsibility of the engine manufacturer and in no way is Swisher or its agents responsible for the engine warranty. The Briggs & Stratton Engine Service Hot-Line is 1-800-233-3723. The Tecumseh Engine Service Hot-Line is 1-800-558-5402.

- 2) Commercial Use This product is not intended for commercial use and carries no commercial warranty.

- 3) Limitation This warranty applies only to products which have been properly assembled, adjusted, and operated in accordance with the instructions contained within this manual. This warranty does not apply to any product of Swisher that has been subject to alteration, misuse, abuse, improper assembly or installation, shipping damage, or to normal wear of the product.

- 4) Exclusions Excluded from this warranty are normal wear, normal adjustments, and normal maintenance.

In the event you have a claim under this warranty, you must return the product to an authorized service dealer. All transportation charges, damage, or loss incurred during transportation of parts submitted for replacement or repair under this warranty shall be borne by the purchaser. Should you have any questions concerning this warranty, please contact us toll-free at 1-800-222-8183. The model number, serial number, date of purchase, and the name of the authorized Swisher dealer from whom you purchased the mower will be needed before any warranty claim can be processed.

THIS WARRANTY DOES NOT APPLY TO ANY INCIDENTAL OR CONSEQUENTIAL DAMAGES AND ANY IMPLIED WARRANTIES ARE LIMITED TO THE SAME TIME PERIODS STATED HEREIN FOR ALL EXPRESSED WARRANTIES. Some states do not allow the limitation of consequential damages or limitations on how long an implied warranty may last, so the above limitations or exclusions may not apply to you. This warranty gives you specific legal rights and you may have other rights, which vary from state-to-state. This is a limited warranty as defined by the Magnuson-Moss Act of 1975.

TABLE OF CONTENTS

| | | | |
|-------------------|------|---------------------------|-------|
| WARRANTY..... | 2 | MAINTENANCE..... | 11-12 |
| INTRODUCTION..... | 3 | SERVICE / ADJUSTMENT..... | 13-16 |
| SAFETY..... | 4-7 | PARTS BREAKDOWN..... | 17-21 |
| OPERATION..... | 8-10 | TROUBLESHOOTING..... | 22 |

Thank you for choosing Swisher's ZTR Mower. Before operating your mower, please read, understand and follow all of the safety precautions and other instructions explained in this manual . As with all power equipment, lawnmowers can be potentially dangerous if improperly used.



SAFETY PRECAUTIONS & DECALS



This Safety Alert Symbol indicates important messages in this manual. When you see this symbol, carefully read the message that follows and be alert to the possibility of personal injury.

Read this manual completely. This machine can amputate hands, feet, and throw objects. Failure to observe the following safety instructions could result in serious injury or death.

- Read the manual. Learn to operate this machine safely.
- Always disconnect the spark plug wire and place the wire where it cannot contact the spark plug, to prevent accidental starting the engine when setting up, transporting, adjusting or making repairs.
- Keep all shields and guards in place.
- Understand the speed, steering and stability of this machine. Know the positions and operations of all controls before you operate this machine. Check all of the controls in a safe area before starting to work with this machine.
- Allow only responsible adults who are familiar with these instructions to operate this machine. **Never allow children to operate this machine.**
- Clear the area of objects such as rocks, toys, wire, etc. that can be picked up and thrown by the blade.
- Be sure the area is clear of other people before mowing. Be aware of the mower discharge direction and do not point at anyone. **Stop the machine** if anyone enters the mowing area. Children are often attracted to the machine and the mowing activity. *Never assume that children will remain where you last saw them.* Keep children under the watchful care of another responsible adult.
- **No riders!**
- Do not put hands or feet near or under rotating parts. Keep clear of the discharge opening at all times.
- Do not mow in reverse. **Always look down and behind before and while backing.**

SAFETY PRECAUTIONS & DECALS

- Turn off the blades when not mowing. Before leaving the machine, turn off the blades and stop the engine.
- Watch for traffic when operating near or crossing roadways.
- Do not operate the mower if it has been dropped or damaged in any manner or if the mower vibrates excessively. Excessive vibration is an indication of damage. Repair mower as necessary.
- Dress properly. Do not operate the mower when barefoot or wearing open sandals. Wear only solid shoes with good traction when mowing. Never allow operation by untrained persons.
- Do not operate the machine while under the influence of alcohol or drugs.
- Operate self-propelled machines up and down slopes. There is significant risk of overturns when operating across slopes. Avoid sudden turns. Operate walk-behind machines across slopes. There is a significant risk of slipping under a walk-behind machine when operating up and down slopes..
- Never tamper with safety devices. Check their proper operation regularly.
- Stop and inspect the equipment if you strike an object. Repair, if necessary, before restarting.
- Never make adjustments or repairs with the engine running.
- Mower blades are sharp and can cut. Wrap the blades or wear gloves, and use extra caution when servicing them.
- Do not operate at too fast a rate.
- Do not mow close to ditches, embankments or drop-offs. An edge could collapse. A mower wheel over the edge could suddenly turn the unit over.
- Do not mow on wet grass if possible. Wet grass causes reduced traction and could cause sliding.
- Do not park on a slope unless absolutely necessary. Always chock or block wheels and set parking brake if parked on slope.

SAFETY PRECAUTIONS & DECALS



WARNING: Hydraulic fluid can cause severe burns and penetrate skin causing severe injury or death.

- Do not step on mower deck when operating, dismounting or mounting the mower.
- Never push or pull unit with another vehicle. Transmission damage will occur.
- When transporting be sure to secure mower frame to transport vehicle. NEVER tie down to moving parts or linkages which may become damaged or come loose.
- NEVER transport mower while engine is running.
- NEVER add fuel or remove gas cap while engine is running or hot.
- NEVER store unit near an open flame such as a water heater or furnace.
- NEVER modify or allow anyone to modify or alter any components or safety devices.
- ALWAYS keep mower clean and free of debris and grass clippings.
- NEVER reverse battery cables. Electric shock will occur.
- ALWAYS keep battery away from open flame and sparks. Explosive gases from battery can cause serious injury or death.
- ALWAYS wear safety glasses and protective gear when servicing battery. Battery fluid contains sulfuric acid. Contact with battery acid on skin or clothing can cause severe chemical burns.
- NEVER tip battery beyond a 45 degree angle in any direction.

SAFETY PRECAUTIONS & DECALS



Danger/Warning Decal – OD99155



Ignition/PTO/Throttle Decal – OD99154

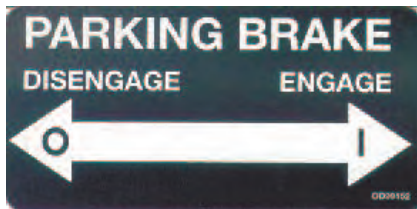

Parking Brake Decal – OD99152

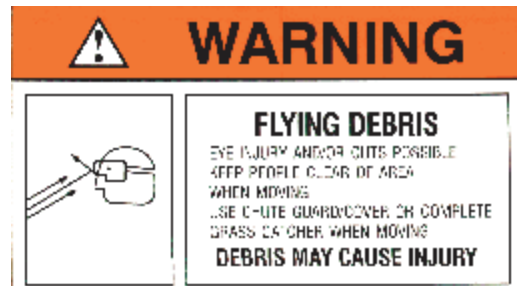

Flying Debris Decal – OD53



Triangle Danger Decal – OD55

OPERATING YOUR NEW ZTR MOWER



The operation of any cutter can encounter foreign objects to be thrown into the eyes, resulting in severe eye damage. Always wear certified safety glasses or wide-vision safety goggles for over spectacles before starting any cutting machine and while operating such a machine.



The operation of any cutter produces sound waves that are damaging to the human ear. Ear protection is recommended.



CAUTION!

Tragic accidents can occur if the operator is not alert to the presence of children. Children are often attracted to the machine and the mowing activity. *Never assume that children will remain where you last saw them.*

SLOPE OPERATION!

Do not operate on slopes greater than 15 degrees. Use extra caution when mowing on slopes. Operate self-propelled units up and down slopes. There is a significant risk of overturns when operating across slopes. If you feel uneasy on a slope then **do not** mow it.

OPERATING YOUR NEW ZTR MOWER (cont.)

CONTROLS

- **OPERATOR PRESENCE SYSTEM:** This mower is equipped with an operator's presence system. Any attempt to leave the seated position while the engine running, without first disengaging the PTO switch and placing the steering levers in the neutral position will cause the engine to shut off.



WARNING: Do not operate the machine unless the Operator's Presence System is functioning as described.

- **PARKING BRAKE:** Always set the parking brake before starting. The parking brake is located on the driver's left hand side. Engage the parking brake by pushing the lever rearward and down until the lever locks into position. Be sure to release the parking brake before operating the machine.
- **IGNITION:** The ignition switch is located on the driver's right hand side toward the rear of the seat. The ignition switch has three positions: OFF, ON, START.
- **THROTTLE:** The throttle/choke control is located on the driver's right hand side towards the front of the seat. For maximum performance and battery charging, operate at full throttle. When starting a cold engine, place the lever forward in the full choke position. After starting, move the throttle rearward to full throttle position. Move the lever all the way to the rear for the lowest setting before shutting off the engine.
- **PTO SWITCH:** The PTO, or Power Take Off switch, is used to engage the blades of the mower. When the PTO switch is pulled out, the blades will be engaged. When the PTO switch is pushed in, the blades will be disengaged. The PTO switch must be pushed in to complete the Operator's Presence System to start the engine.
- **NEUTRAL LOCK:** The steering levers must be in the **outward and locked** position for the mower to start the engine. (See page 13)

STARTING MOWER

- **TO START:** Position steering handles outward to neutral locked position. Engage parking brake. Extend throttle to full choke position. Start ignition and slide throttle lever back to full throttle position. Allow engine to warm up for 1 minute. Release parking brake.
- **FORWARD MOVEMENT:** To move the mower forward, gently push both steering levers forward equal distance from the neutral position. The further you move the levers forward, the faster you will travel. **CAUTION:** steering levers have quick response timing.
- **BACKWARD MOVEMENT:** To move the mower backwards, gently pull back on the steering levers the same distance from neutral. The further you pull back, the faster you will travel. **NOTE:** it is normal for the reverse speed to be less than the forward for easier turning.
- **TURNS:** For left turn, move the right lever farther forward than the left. For right turn, move the left lever farther forward than the right. To obtain a tight turning radius, **GENTLY** reverse one lever and push the other lever forward. **CAUTION:** Aggressive turns can damage lawns. Do not make turns with the inside wheel stopped. It is better to keep both wheels turning slightly.
- **DECK HEIGHT ADJUSTMENT:** To raise the mower deck up and down, simply rotate the lever located in front of the seat above the floor plate. Clockwise raises the deck. Counterclockwise lowers the deck. The deck is adjustable from 1 1/2" to 3 1/2".
- For best performance, grass over 6 1/2" in height should be mowed once in the highest position and once again at desired cut height.
- **ENGAGING BLADES:** Operator must be seated for operation of blades. With engine to full throttle position, pull UP on PTO switch located between the throttle and the key switch. To disengage blades, push DOWN on PTO switch.
- **STOPPING ENGINE:** Place both levers in the outward neutral locked position. Push PTO switch in to disengage. Place throttle lever to lowest setting and let idle for 30 seconds. Turn off ignition key and engage parking brake.

OPERATING YOUR NEW ZTR MOWER (cont.)

MOWING



WARNING: Do not operate mower at too fast of a rate. Sudden movements forward and backward at fast speeds can cause accidents resulting in personal injury

- Start out slowly moving steering levers **SLOWLY** forward and backward until you learn to operate the unit. **NOTE:** This mower has been designed to be very maneuverable. Practice is extremely necessary in open, flat areas to become comfortable and efficient with the controls.
- **BEGIN TO MOW:** Before starting the engine, set the desired deck height.
- Start the mower engine.
- Position the throttle lever about halfway and engage PTO switch. Reposition throttle lever to full throttle position.
- Move steering levers forward to begin mowing.



CAUTION: Always make sure the deck is not plugged with grass or other debris. Failure to do this will cause damage to the PTO belt.

- **STOPPING:** Hydrostatic mowers use hydrostatic braking through the transmissions. To slow or stop the unit move the steering levers to the neutral position
- **STOPPING THE ENGINE:** Move the throttle lever to slow position, allow engine to idle for 30 seconds and turn ignition to off position. **CAUTION:** Failure to position the ignition key to any position except off will cause discharge of the battery.

MAINTENANCE SCHEDULE

INSPECT BEFORE EACH USE

-Loose fasteners: Be sure all fasteners are at proper torque. Especially guards and blades.

-Parking brake: If brake does not keep unit from rolling, brake must be adjusted or repaired.

-Tires: Always check and maintain proper tire pressure (See tire sidewall for recommendation). Check for damage due to sharp rocks, objects or stumps.

-Operator Presence System: The engine should not start unless the PTO switch is disengaged and the control levers are locked in the neutral position. Any attempt to leave the seated position with the PTO switch engaged will kill the engine.

-Oil level: To prevent damage to engine, always check and maintain proper oil level. Never operate engine with the oil level below the add mark on the dipstick. Be sure to tighten the dipstick securely after inspection. Refer to engine manual for additional information.

INSPECT EVERY 8 HOURS

-Proper cleaning: Remove any build up of grass, dirt or debris with a brush or cloth from engine, battery, deck and transaxles. Do not use harsh chemicals or abrasives. Keep all painted surfaces and wheels free of oil and gasoline. Protect all painted surfaces with an automotive wax. Do not spray unit with water or store outdoors unprotected. Water can invade sealed bearings and reduce component life.



Do not spray water onto hydrostatic transmissions. This will cause injection of water into the unit causing failure.

-Air filter: The engine will not run properly with a dirty or damaged air filter. Check filter before starting the engine. Check for buildup of dirt or debris. Replace if bent clogged or damaged.

-Oil level: To prevent damage to engine, always check and maintain proper oil level. Never operate engine with the oil level below the add mark on the dipstick. Be sure to tighten the dipstick securely after inspection.

MAINTENANCE SCHEDULE

INSPECT EVERY 25 HOURS

- Lubrication:** Grease all pivot points with a high temp grease
- Battery, check and clean:** Keep battery terminals clean and tight. Periodic charging will extend its life. Clean terminals with a wire brush and coat with a petroleum jelly.
- Change engine oil and filter:** Use only quality detergent oil. See engine manual for instructions. Select viscosity grade according to your expected environmental temperature.
- Blades:** Best results will come from sharp blades. Replace if bent, damaged or worn.
- Engine air screen:** Screen must be clean and free of debris for proper engine cooling. Clean with a brush or cloth. Do not spray with pressurized water.
- Muffler:** Inspect for damage or corrosion. Keep free of grass or debris to prevent fire.

INSPECT CHECK EVERY 100 HOURS

- Clean engine cooling fins:** Clogged cooling fins can damage engine due to overheating.. Keep fins and external surfaces of the engine clean.
- Replace air filter:** The engine will not run properly with a dirty or damaged air filter. Check filter before starting the engine. Check for buildup of dirt or debris. Replace if bent clogged or damaged. See engine manual for detailed instructions.
- Replace spark plugs:** See engine manual for detailed instructions.

INSPECT EACH SEASON

- Belts:** Check belts for wear and deterioration. See service and adjustments.
- Spark plug:** See engine manual for detailed instructions.
- Replace in-line fuel filter:** Replace every season.

INSPECT BEFORE STORAGE

- Change engine oil and filter:** See engine manual for detailed instructions.
- Lubrication:** Grease all pivot points with a high temp grease.
- Check battery:** Keep battery terminals clean and tight. Periodic charging will extend its life. Clean terminals with a wire brush and coat with a petroleum jelly.
- Loose fasteners:** Be sure all fasteners are at proper torque. Especially guards and blades.

SERVICE / ADJUSTMENTS

⚠ CAUTION: Before performing any service or adjustments do as follows:

1. Turn off PTO switch.
2. Position unit on smooth flat surface.
3. Place steering levers in outward, neutral-locked position.
4. Turn ignition key “OFF” and set parking brake.
5. Wait for all moving parts to stop and disconnect spark plug wire.

TRACKING

Adjustments to the unit may need to be made if the unit does not track in a straight line. The primary reason for the unit not tracking straight is incorrect or unbalanced tire pressure. Before making any adjustments first check and adjust the tire pressure. **DO NOT EXCEED MAXIMUM RECOMMENDED TIRE PRESSURE.**

ADJUST LINKAGE: Place steering levers outward locking them in the neutral position. Turn off engine and raise seat. Under the seat are (4) adjustment bolts. The two adjustment bolts toward the seat mount are adjustments for the forward travel. The two bolts toward the engine are for the reverse travel. Clockwise movement for these adjustments will decrease or slow the travel speed of the individual side. Counterclockwise movement will increase the travel of the individual side. The linkage is factory set to maximum performance. Adjustment is made by rotating the adjustment bolt clockwise on the opposite side that the unit tracks toward. Adjust forward and reverse to track straight as needed. When accomplished adjustment to the steering levers may need to be done. This is made by loosening the the two bolts on the steering lever and aligning with the other. Travel of the steering levers from front to rear may be accomplished in the same manner.

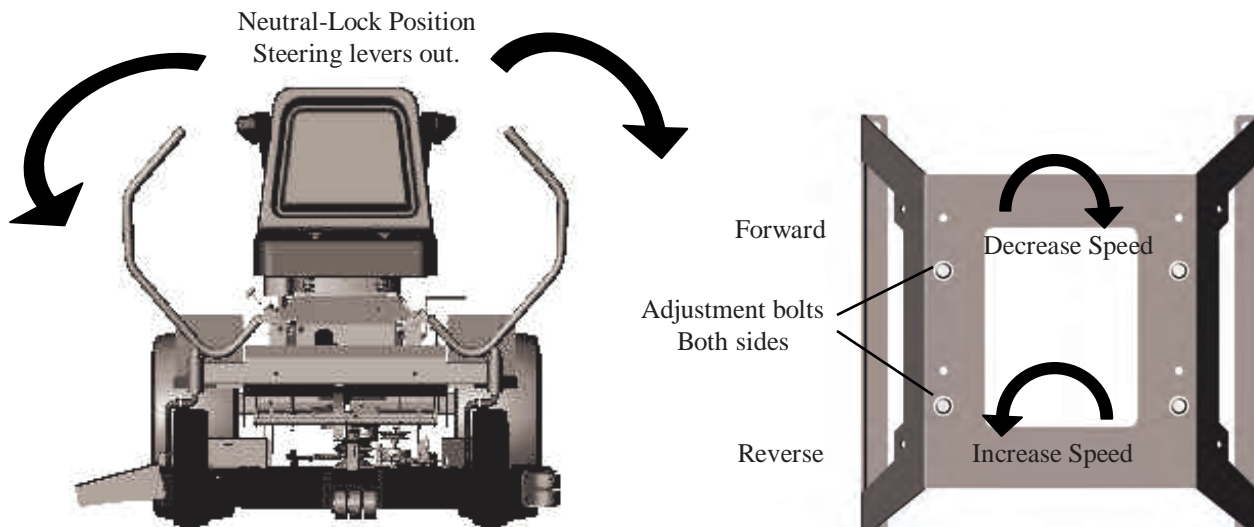

SERVICE / ADJUSTMENTS

REMOVING THE MOWER DECK

1. Turn off engine and engage parking brake.
2. Rotate cutting height lever counterclockwise to lowest cutting position.
3. Remove bolt from pickup point located at the front of the deck.
4. Remove cotter pins on rear hanger points and slide out stabilizer bars. Disconnect tension spring bolt from tension bracket.
5. Remove belt from mower pulley and electric clutch.
6. Slide mower deck from under unit.

INSTALLING THE MOWER DECK

1. Be sure the cutting height lever is in the lowest position.
2. Position mower deck under unit.
3. Install belt around mower pulley and electric clutch.
4. Install stabilizer bars into rear hanger brackets through lift points and install cotter pins. Be sure eye bolt is between bracket sides.
5. Install bolt in front hanger bracket passing through eyebolt in the same manner as rear and tighten snug.
6. Reattach tension spring bolt and tighten.

It is recommended to remove the deck to sharpen the blades.

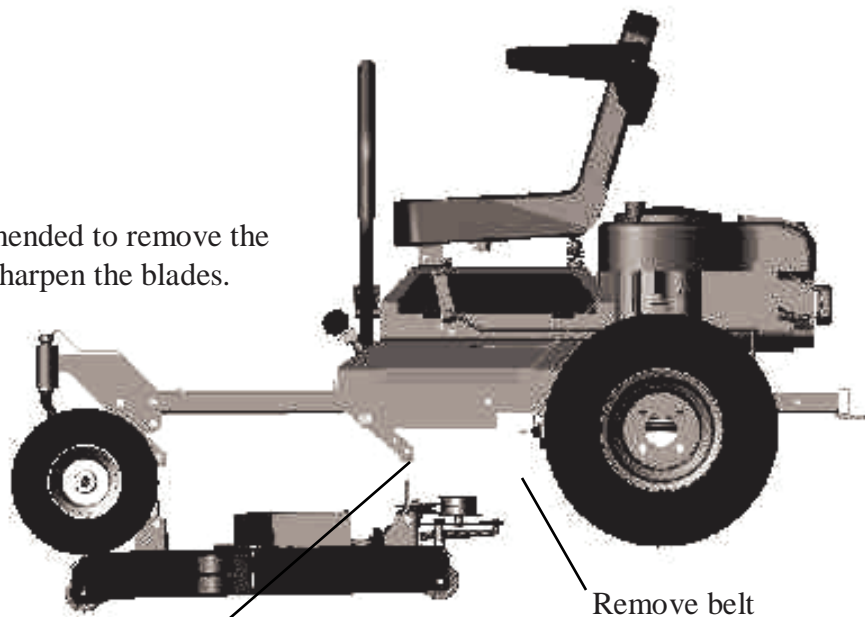

Remove eye-bolts (3: 2 rear & 1 front)

Remove belt

SERVICE / ADJUSTMENTS

LEVELING THE MOWER DECK

1. Position unit on a smooth level surface.
2. For side to side leveling, measure the distance from the floor to the bottom edge at the rear of the deck. The measurement should be equal within 1/16 inch side to side. Adjustment can be made by loosening locking nut on rear eyebolt hangers and adjusting up or down as needed.
3. For front to rear pitch adjustment, loosen locking nut on front eyebolt and adjusting up or down as needed. Proper pitch measurement is 1/8" to 1/4" lower at the front of the deck.

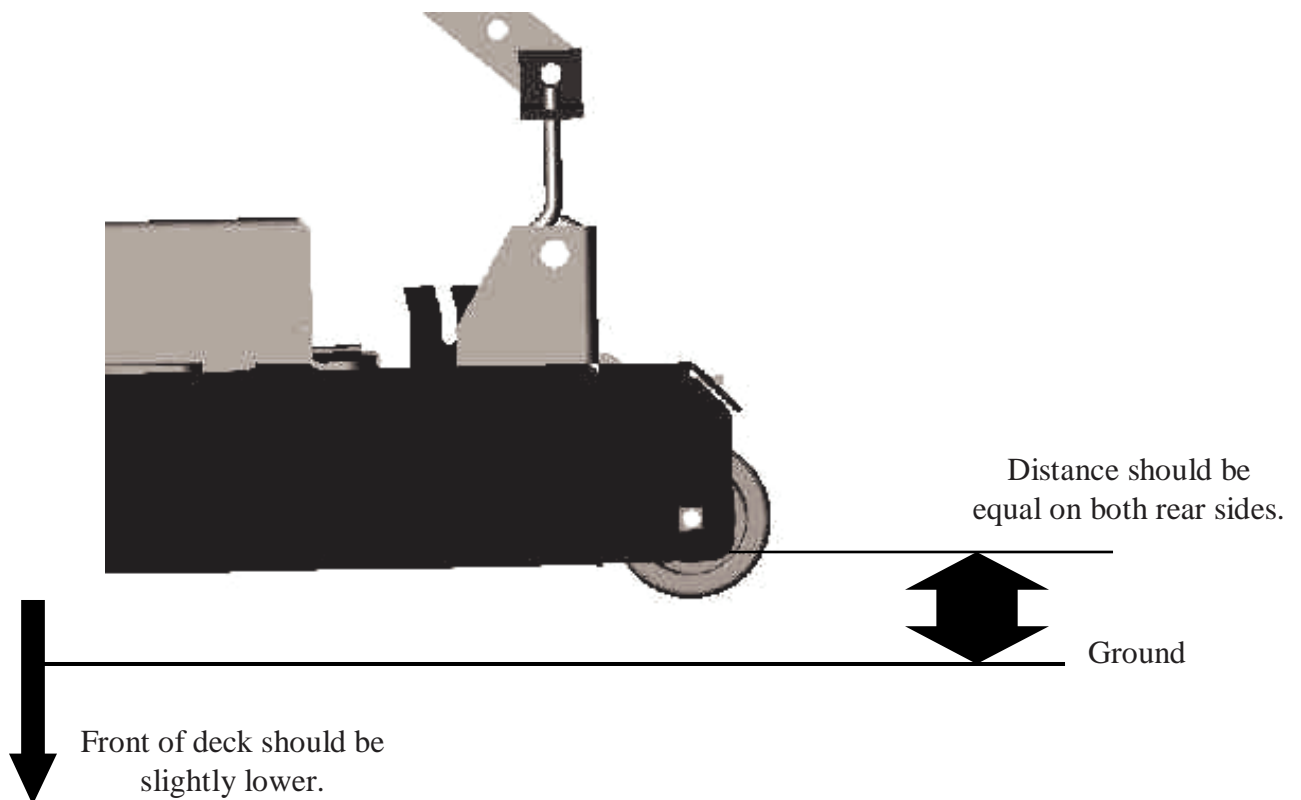

SERVICE / ADJUSTMENTS

BELTS

Clutch drive belt replacement

1. Disconnect tension idler from tension bracket.
2. Remove belt from mower pulley and electric clutch.
3. Install new belt onto electric clutch and mower pulley and check for proper routing and clearance.
4. Reconnect idler tension bolt to tension bracket.

Mower deck belt replacement

1. Remove clutch drive belt. *See previous procedure.*
2. Remove belt covers.
3. Disconnect idler tension spring.
4. Remove deck belt.
5. Install new belt, check for proper routing and clearance.
6. Reinstall clutch drive belt.

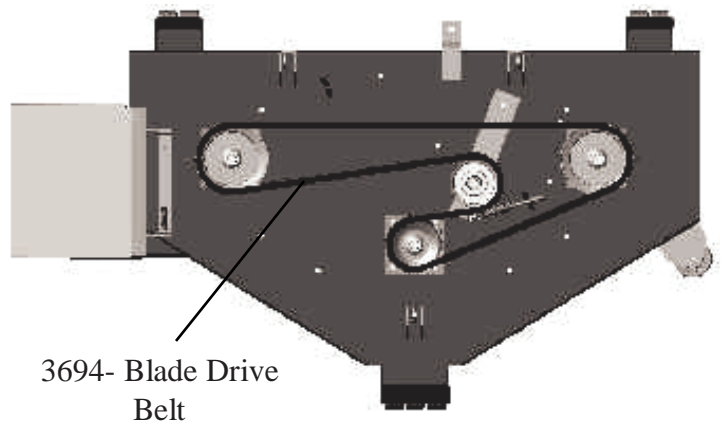
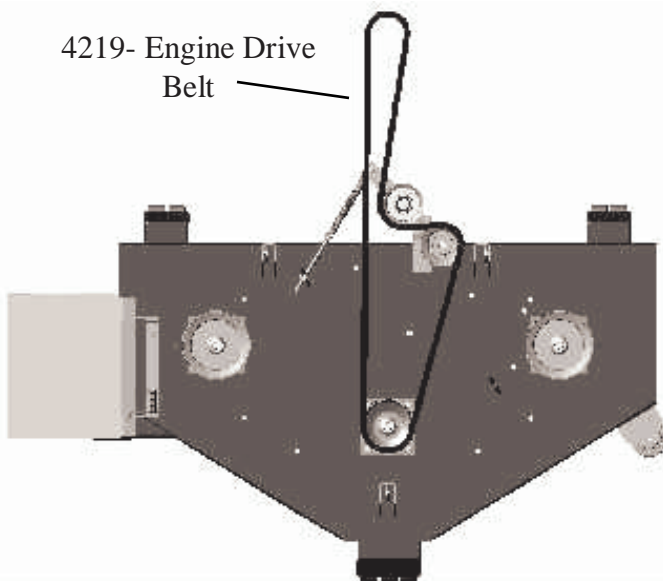

Transaxle belt replacement

1. Remove clutch drive belt. *See clutch belt replacement previous page.*
2. Disconnect wiring from electric clutch.
3. Disconnect idler spring from tension bracket.
4. Remove bolt and washer from bottom of electric clutch and slide clutch from engine crankshaft, set aside.
5. Remove belt from transaxles and engine pulley.
6. Install new belt. Check for proper routing and clearance.
7. Reinstall electric clutch carefully aligning keyed portion of clutch and keyway in crankshaft. Reinstall bolt and washer. Washer is "cupped" be sure to place "cupped" side of washer towards the clutch body.
8. Reconnect tension idler to tension bracket.
9. Reconnect wiring harness to electric clutch.
10. Reinstall clutch drive belt. *See clutch belt replacement previous page.*

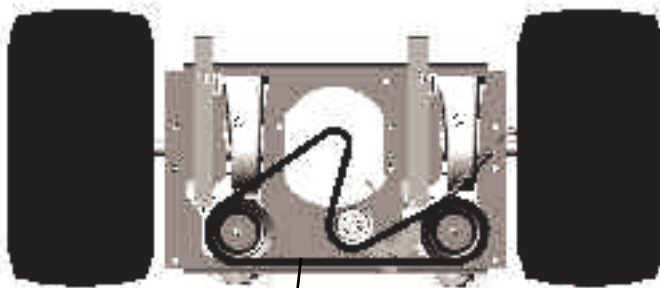

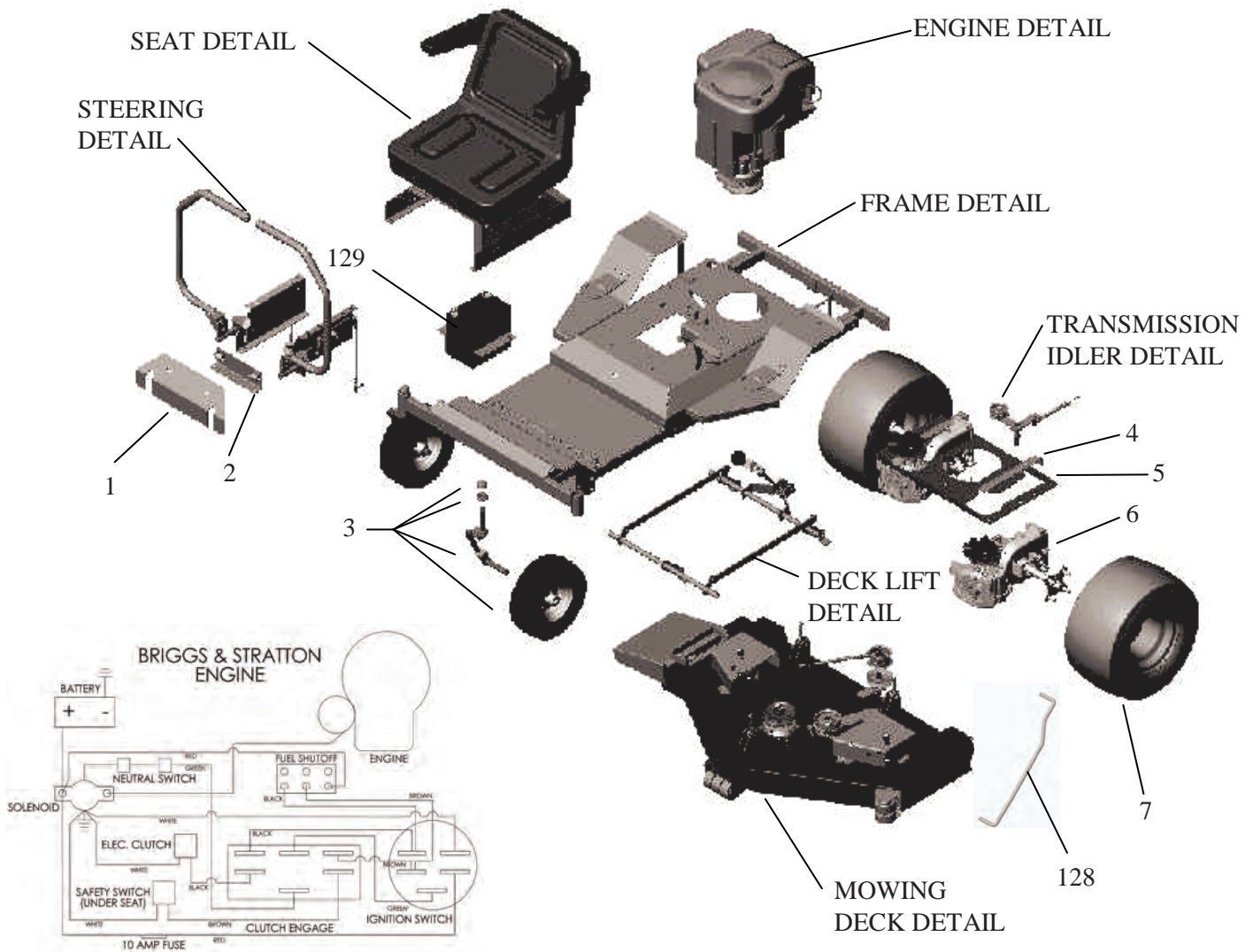

OVERALL ASSEMBLY

| ITEM # | DESCRIPTION | PART # |
|-----------|---------------------------|--------|
| 1 | STEERING COVER | 3644 |
| 2 | NEUTRAL SWITCH BRACKET | 3704TK |
| | NEUTRAL SWITCH | 3695 |
| 3 | ZTR CASTER SERVICE ASSEM. | 3725 |
| 4 | HYDRO RELEASE | 3678TK |
| 5 | TRANSMISSION MOUNT | 3703TK |
| 6 | TRANSMISSION LEFT | 3601CB |
| | TRANSMISSION RIGHT | 3600CB |
| 7 | TIRE/WHEEL - 18 X 9.50-8 | 3604 |
| 128 | SWAY BAR LEFT | 3665 |
| | SWAY BAR RIGHT | 3664 |
| 129 | BATTERY BRACKET | 3696TK |
| NOT SHOWN | WIRING HARNESS | 3720 |
| | SOLENOID | 16915 |
| | DECK BELT | 3694 |
| | ENGINE TO DECK BELT | 4219 |
| | TRANSMISSION BELT | BA50 |

BLADE DRIVER

ENGINE SET-UP

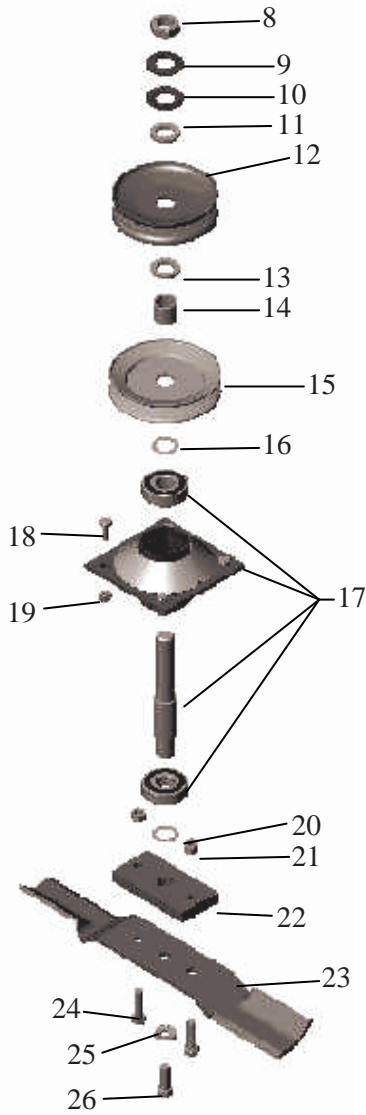

TRANSMISSION IDLER (3715)

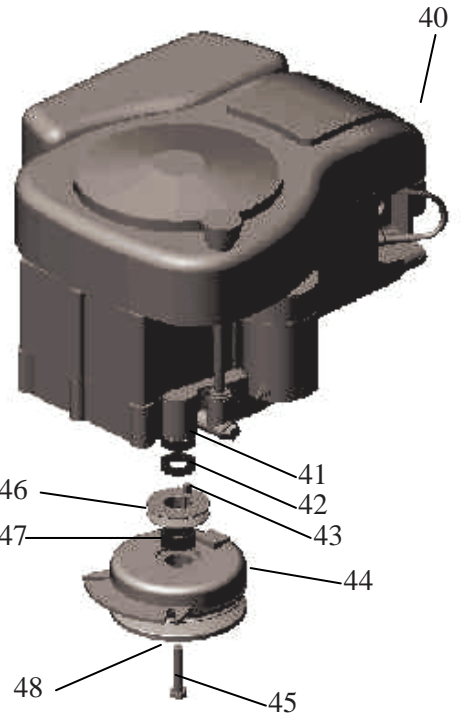
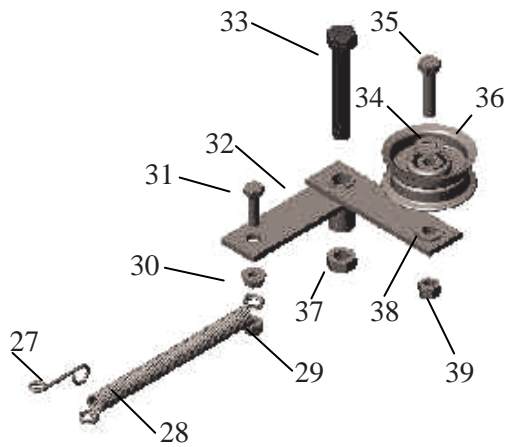

| ITEM # | DESCRIPTION | PART # |
|--------|----------------------------|--------|
| 8 | 3/4 NUT | NB175 |
| 9 | BELLEVILLE WASHER | AS155 |
| 10 | BELLEVILLE WASHER | AS155 |
| 11 | WASHER | NB184 |
| 12 | BLADE PULLEY | B104 |
| 13 | WASHER | NB184 |
| 14 | PULLEY SPACER | 6114CS |
| 15 | BLADE PULLEY 4 1/2" | B4104 |
| 16 | WASHER | 9021 |
| 17 | BLADE DRIVER ASMBLY CENTER | 9058 |
| | BLADE DRIVER ASMBLY R&L | 9018 |
| 18 | 1/4 BOLT | NB250 |
| 19 | 1/4 NUT | NB180 |
| 20 | WASHER | 9021 |
| 21 | 3/8 LOCKNUT | NB216 |
| 22 | BLADE MOUNT PLATE | 9008 |
| 23 | BLADE 15" | 4221 |
| 24 | 3/8 BOLT | NB166 |
| 25 | BELLEVILLE WASHER | NB607 |
| 26 | 3/8 BOLT | NB238 |

| ITEM # | DESCRIPTION | PART # |
|--------|------------------|--------|
| 27 | WIRE LINK | BRS6H |
| 28 | SPRING | 682S |
| 29 | 5/16 NUT | NB181 |
| 30 | 5/16 FLANGE NUT | NB170 |
| 31 | 5/16 BOLT | NB501 |
| 32 | TRANS. IDLER ARM | 3690TK |
| 33 | 1/2 BOLT | NB131 |
| 34 | 3/8 WASHER | NB272 |
| 35 | 3/8 BOLT | NB107 |
| 36 | IDLER PULLEY | B27 |
| 37 | 1/2 NUT | NB121 |
| 38 | 3/8 WASHER | NB272 |
| 39 | 3/8 NUT | NB280 |

| ITEM # | DESCRIPTION | PART # |
|--------|-----------------------|------------|
| 40 | ENGINE | NOT AVAIL. |
| 41 | ENGINE PULLEY SPACER | BB105SL |
| 42 | ENGINE PULLEY SPACER | BB105SL |
| 43 | 1/4 X 1/2 KEY | 4258 |
| 44 | ELECTRIC CLUTCH | 688EC |
| 45 | 7/16 BOLT | NB685 |
| 46 | ENGINE PULLEY | 2411 |
| 47 | ENGINE PULLEY SPACER | 689S |
| 48 | BELLEVILLE WASHER (2) | 699 |

SEAT BASE ASSEMBLY

STEERING (LEFT)

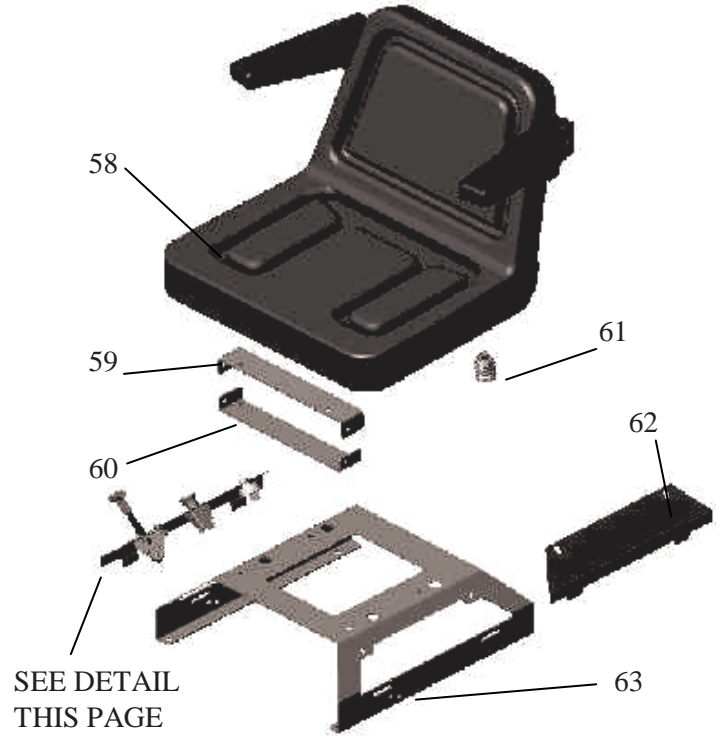
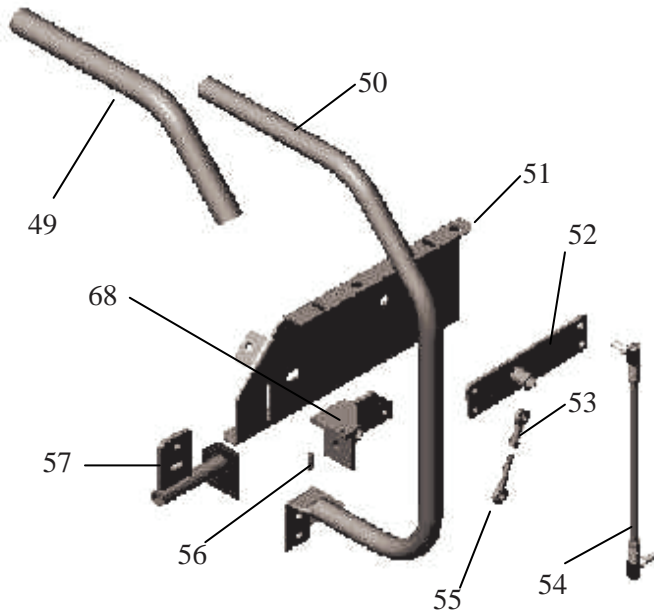

CONTROL CARD

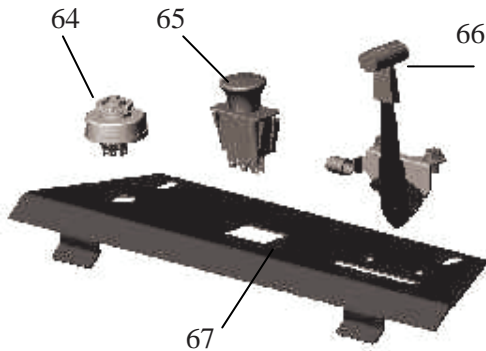

| ITEM # | DESCRIPTION | PART # |
|--------|------------------------|--------|
| 49 | HANDLE GRIP | 3673 |
| 50 | DIRECTIONAL HANDLE | 3685TK |
| 51 | CONTROL CARD LEFT | 3620TK |
| | CONTROL CARD RIGHT | 3621TK |
| 52 | UNIVERSAL PIVOT PLATE | 3698TK |
| 53 | CONNECTOR (FEMALE) | 3608 |
| 54 | DIREC. CONTROL LINKAGE | 3670 |
| 55 | CONNECTOR (MALE) | 3721 |
| 56 | 1/4 SET SCREW | NB310 |
| 57 | HANDLE MOUNT LEFT | 3636TK |
| | HANDLE MOUNT RIGHT | 3635TK |
| 58 | SEAT ASSEMBLY | 3724 |
| | ARM REST KIT | 3603 |
| 59 | SEAT BRACKET | 3662TK |
| 60 | SEAT BRACKET | 3661TK |
| 61 | SPRING | 3609 |
| 62 | RIGHT CONTROL COVER | 3726 |
| 63 | SEAT MOUNT | 3613TC |
| 64 | KEY SWITCH | 3623 |
| 65 | PTO SWITCH | 3605 |
| 66 | THROTTLE CABLE ASSY | 3640 |
| 67 | LEFT CONTROL COVER | 3722 |
| 68 | LEFT PIVOT WELDMENT | 3700TK |
| | RIGHT PIVOT WELDMENT | 3699TK |

FRAME

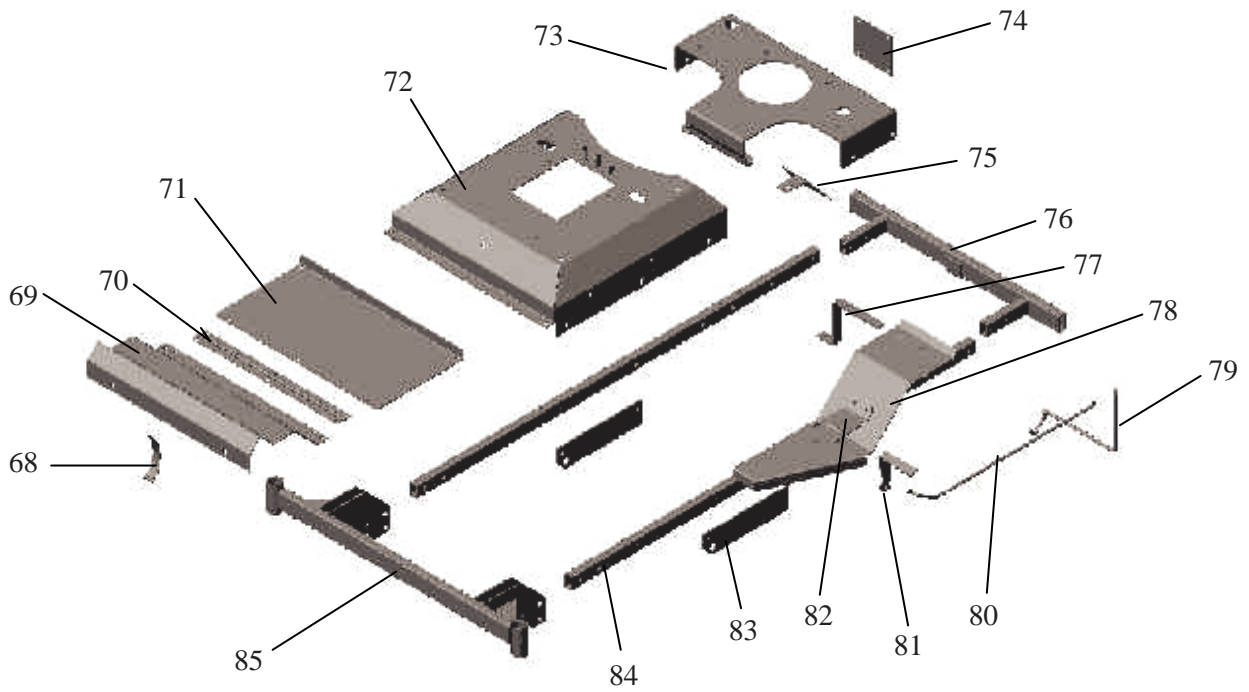

DECK LIFT

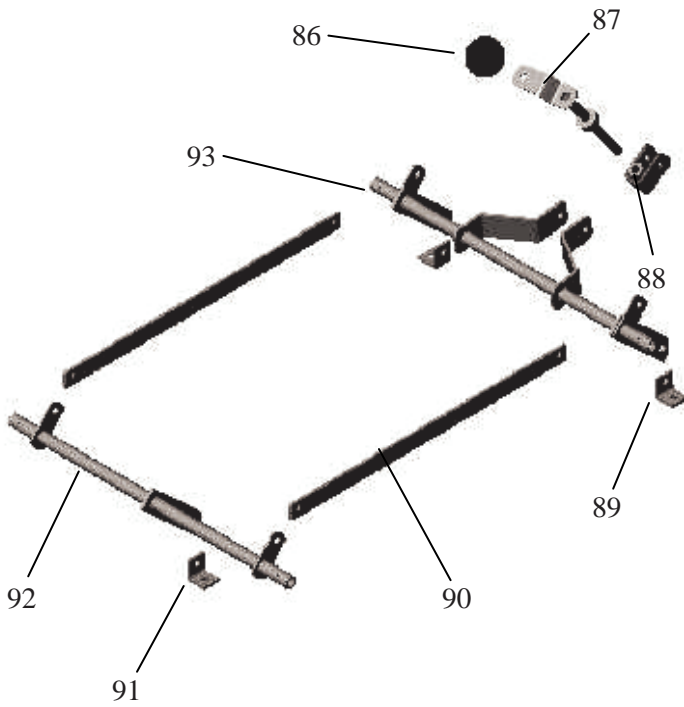

| ITEM # | DESCRIPTION | PART # |
|--------|---------------------|-----------------|
| 68 | HEIGHT INDICATOR | 3728 |
| 69 | KICK PLATE | 3729 |
| 70 | ACCESS PLATE HINGE | 3675TK |
| 71 | ACCESS PLATE | 3631TK |
| 72 | SEAT BASE | 3730 |
| 73 | UPPER MOTOR BASE | 3611TK |
| 74 | REAR COVER | 3711TK |
| 75 | TRANS. FAN COVER | 3712TK |
| 76 | BUMPER | 3686TK |
| 77 | FENDER MOUNT | 3654TK |
| 78 | FENDER LEFT | 3011TK & 5142TK |
| | FENDER RIGHT | 3012TK & 5142TK |
| 79 | E - BRAKE REAR LINK | 3652 |
| 80 | E - BRAKE SIDE LINK | 3651 |
| 81 | BRAKE LEVER | 3731 |
| 82 | BEVERAGE RETAINER | 3643TK |
| 83 | REAR HANGER BRACKET | 3693TK |
| 84 | FRAME SIDE | 3614TK |
| 85 | FRONT FRAME | 3650TK |
| 86 | PLASTIC KNOB | 4857 |
| 87 | HEIGHT ADJUST CRANK | 3266TK |
| 88 | HEIGHT LIFTER | 3705TK |
| 89 | LIFT PIVOT | 3663TK |
| 90 | HEIGHT LINK | 3660TK |
| 91 | LIFT PIVOT | 3663TK |
| 92 | FRONT TORSION | 3683TK |
| 93 | REAR TORSION | 3684TK |

MOWING DECK

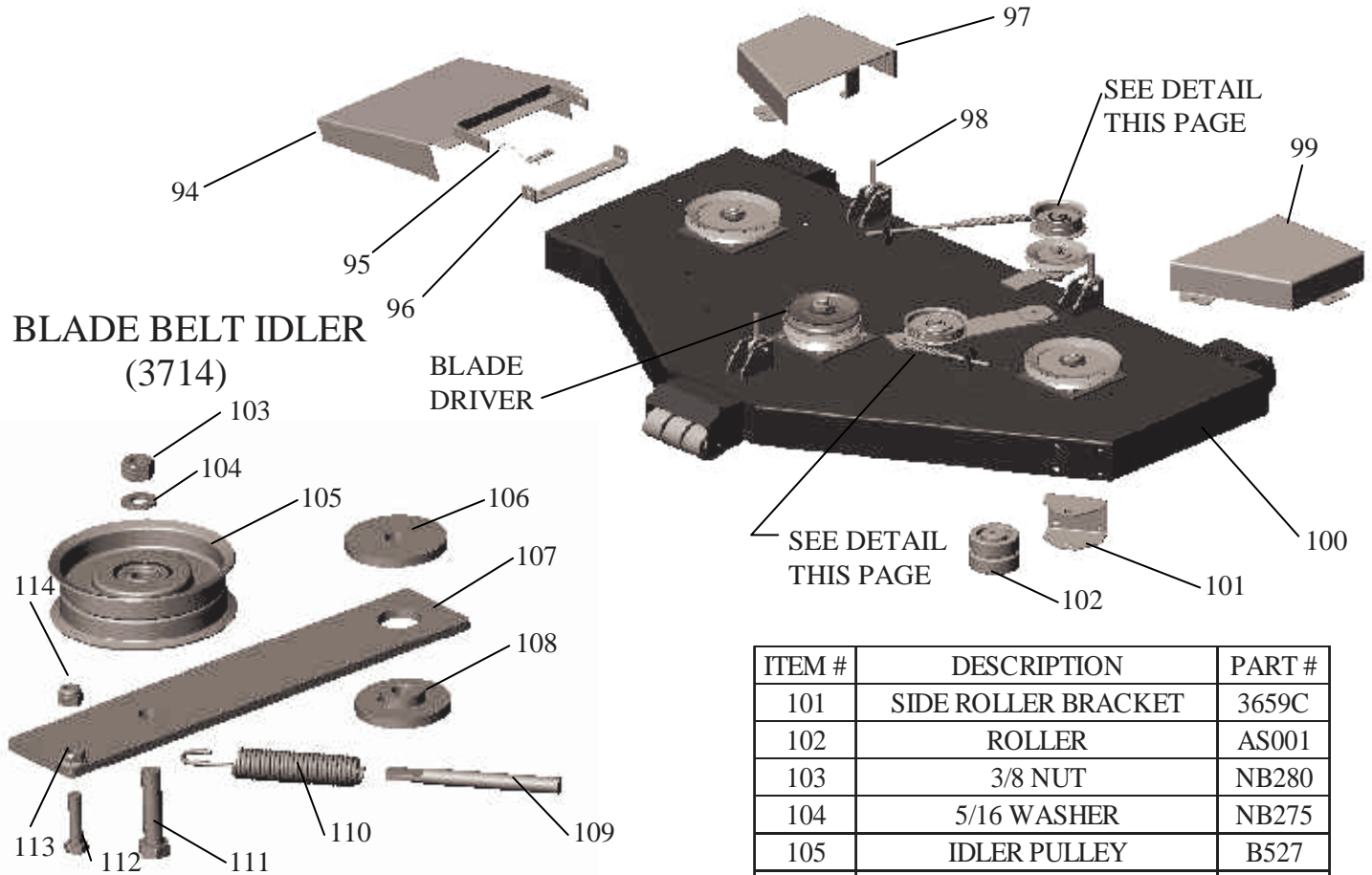

LOWER BELT IDLER (3713)

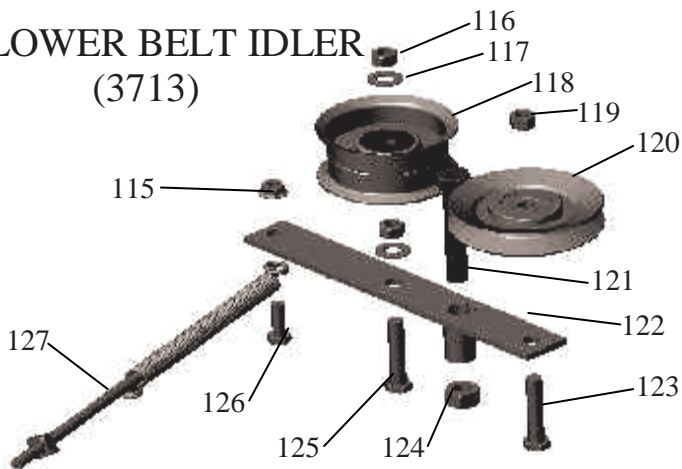

| ITEM # | DESCRIPTION | PART # |
|--------|-------------------|--------|
| 94 | GRASS CHUTE | 3668TK |
| 95 | TORSION SPRING | 166X34 |
| 96 | CHUTE MOUNT | 6030TK |
| 97 | BELT/PULLEY COVER | 3656TK |
| 98 | 3/8 EYE BOLT | NB204 |
| 99 | BELT/PULLEY COVER | 3658TK |
| 100 | MOWER DECK | 3762TC |

| ITEM # | DESCRIPTION | PART # |
|--------|----------------------|--------|
| 101 | SIDE ROLLER BRACKET | 3659C |
| 102 | ROLLER | AS001 |
| 103 | 3/8 NUT | NB280 |
| 104 | 5/16 WASHER | NB275 |
| 105 | IDLER PULLEY | B527 |
| 106 | IDLER SPACER | 6040 |
| 107 | TENSION IDLER ARM | 3676TK |
| 108 | IDLER BUSHING | 6037 |
| 109 | 5/16 SPADE BOLT | NB261 |
| 110 | IDLER TENSION SPRING | 6048 |
| 111 | 3/8 BOLT | NB107 |
| 112 | 1/4 BOLT | NB102 |
| 113 | 1/4 FLANGE NUT | NB524 |
| 114 | 1/4 NYLOK NUT | NB180 |
| 115 | 5/16 FLANGE NUT | NB170 |
| 116 | 3/8 NUT | NB280 |
| 117 | 3/8 WASHER | NB272 |
| 118 | IDLER PULLEY | 7509 |
| 119 | 3/8 NUT | NB280 |
| 120 | IDLER PULLEY | 3622 |
| 121 | 1/2 BOLT | NB131 |
| 122 | LOWER BELT IDLER ARM | 3691TK |
| 123 | 3/8 BOLT | NB231 |
| 124 | 1/2 NUT | NB213Z |
| 125 | 3/8 BOLT | NB231 |
| 126 | 5/16 BOLT | NB501 |
| 127 | ENGAGEMENT ROD | B25RT |

TROUBLESHOOTING

| SYMPTOM | CAUSE | CORRECTION |
|---|---|---|
| ENGINE HARD TO START | <ol style="list-style-type: none"> 1. WEAK OR DEAD BATTERY 2. AIR FILTER DIRTY 3. BAD SPARK PLUG 4. FUEL FILTER DIRTY 5. STALE OR CONTAMINATED FUEL 6. CARBURATOR OUT OF ADJUSTMENT | <ol style="list-style-type: none"> 1. REPLACE OR RECHARGE 2. CLEAN OR REPLACE 3. REPLACE SPARK PLUG 4. REPLACE FUEL FILTER 5. DRAIN AND REPLACE WITH FRESH FUEL 6. CONTACT NEAREST BRIGGS&STRATTON SERVICE REPRESENTATIVE |
| ENGINE WILL NOT START OR LOSS OF POWER | <ol style="list-style-type: none"> 1. STEERING LEVERS NOT IN NEUTRAL LOCKED POSITION 2. PTO SWITCH IS ENGAGED 3. THROTTLE NOT SET PROPERLY OR NOT PROPERLY "CHOKED" 4. ENGINE FLOODED 5. DIRTY FUEL FILTER 6. DIRTY AIR FILTER 7. CONTAMINATED FUEL 8. BLOWN FUSE 9. BAD SPARK PLUG OR LOOSE PLUG WIRE 10. DIRTY ENGINE AIR SCREENS 11. WEAK OR DEAD BATTERY 12. CARBURATOR OUT OF ADJUSTMENT 13. OUT OF FUEL 14. CORRODED BATTERY TERMINALS 15. LOOSE OR DAMAGED WIRING 16. LOW OR DIRTY OIL 17. DEBRIS BUILT-UP UNDER DECK | <ol style="list-style-type: none"> 1. MOVE LEVERS INTO POSITION. 2. PUSH PTO SWITCH IN. 3. SEE START UP IN OPERATION SECTION. 4. WAIT SEVERAL MINUTES BEFORE STARTING 5. REPLACE WITH NEW FILTER 6. REPLACE OR CLEAN 7. DRAIN AND REPLACE WITH FRESH FUEL 8. REPLACE FUSE 9. REPLACE PLUG AND TIGHTEN PLUG WIRE 10. CLEAN ENGINE AIR SCREENS 11. REPLACE OR RECHARGE 12. CONTACT NEAREST BRIGGS&STRATTON SERVICE REPRESENTATIVE 13. REPLACE WITH FRESH FUEL 14. CLEAN TERMINALS 15. CONTACT SWISHER SERVICE REPRESENTATIVE 16. CHECK LEVEL/CHANGE OIL 17. CLEAN UNDERSIDE OF MOWER |
| UNIT DOES NOT TRACK STRAIGHT | <ol style="list-style-type: none"> 1. IMPROPER AIR PRESSURE 2. TRACKING ADJUSTMENTS OUT OF ADJUSTMENT | <ol style="list-style-type: none"> 1. CHECK ANDADJUST TIRE PRESSURE 2. SEE TRACKING ADJUSTMENT IN SERVICE SECTION |



swisherinc.com

OWNER'S MANUAL

**MODEL NO.
ZT17542**

"Z" SERIES

ZERO TURN HYDROSTATIC DRIVE

Each mower has its own model number. Each engine has its own model number. The model number for the mower will be found under the seat. The model number for the engine will be found on the top of the blower fan housing.

All mower parts listed herein may be ordered directly from Swisher or your nearest Swisher dealer.

All engine parts may be ordered from the nearest dealer of the engine supplied with your mower.

WHEN ORDERING PARTS, PLEASE HAVE THE FOLLOWING INFORMATION AVAILABLE:

- * PRODUCT - ZT17542
- * SERIAL NUMBER - _____
- * MODEL NUMBER - _____
- * ENGINE MODEL NUMBER - _____
- TYPE - _____
- * PART NUMBER WITH PAINT CODE
- * PART DESCRIPTION

TELEPHONE - 1-800-222-8183

FAX - 1-660-747-8650

SWISHER

1602 CORPORATE DRIVE

WARRENSBURG, MO 64093



SWISHER